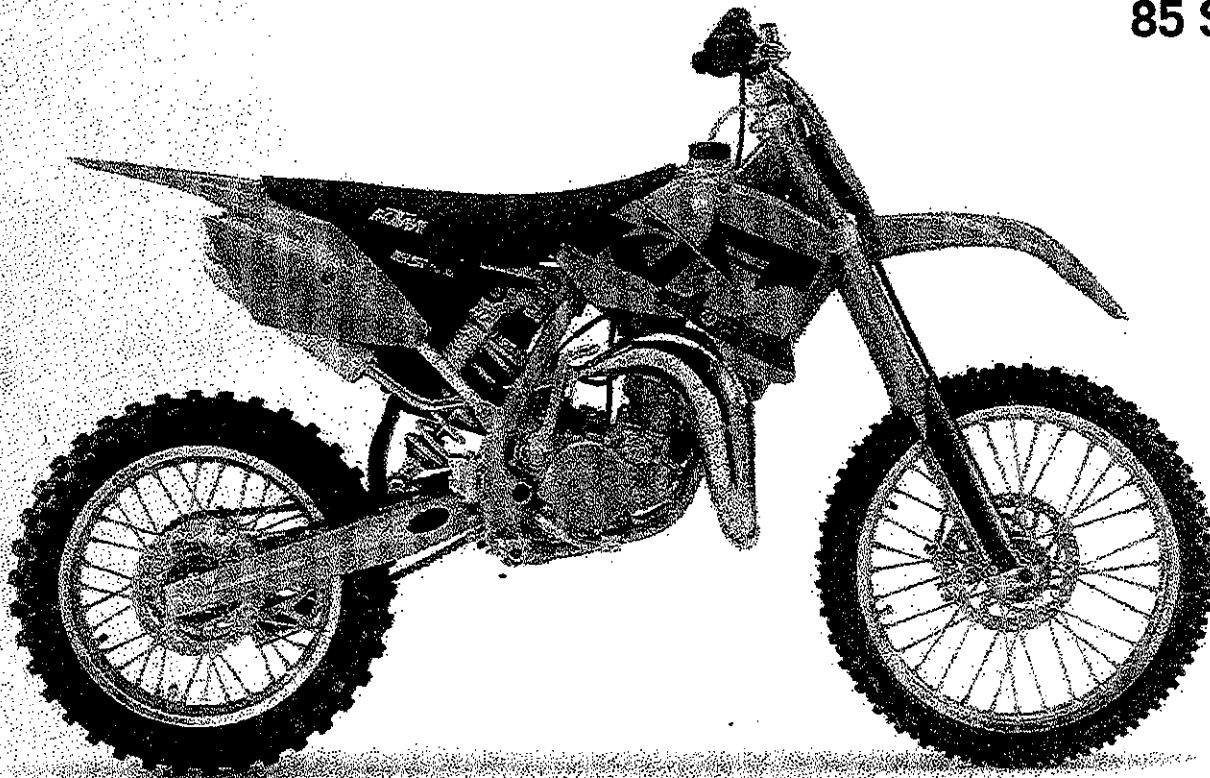


SPAREPARTS MANUAL 2004

ERSATZTEILKATALOG: FAHRGESTELL + MOTOR
SPARE PARTS MANUAL: CHASSIS + ENGINE
85 SX



MOTOTECH
MOTORCYCLE TECHNOLOGY

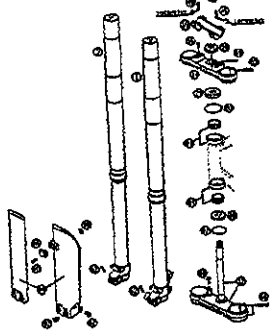
KTM



INHALTSVERZEICHNIS

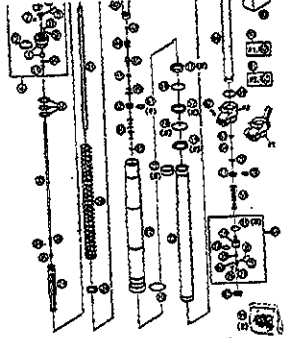
INDEX

TELEGABEL WP USD 43
FRONT FORK WP USD 43



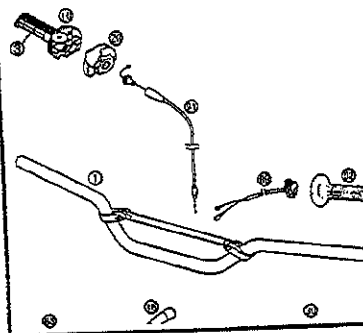
SEITE
Page
4

GABELBEINE WP USD 43
FORK LEGS WP USD 43



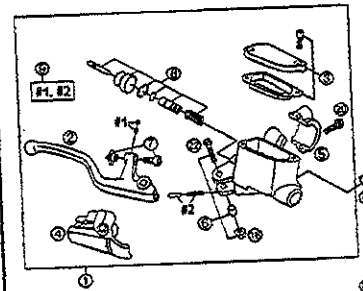
SEITE
Page
5

LENKER, ARMATUREN
HANDLEBAR, CONTROLS



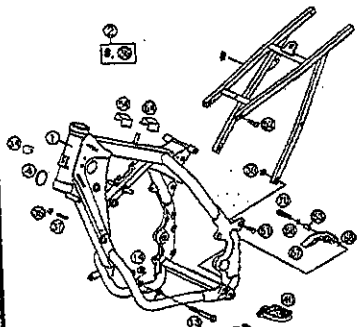
SEITE
Page
7

HANDBREMSZYLINDER FORMULA
HAND BRAKE CYLINDER FORMULA



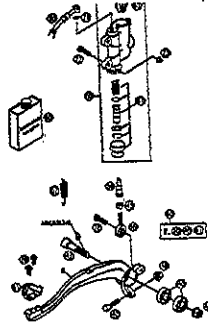
SEITE
Page
8

RAHMEN, AUSLEGER
FRAME, SUB FRAME



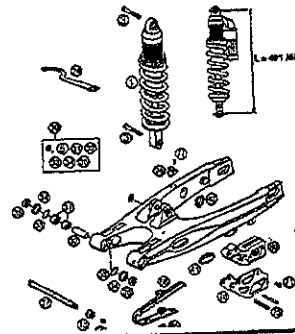
SEITE
Page
9

FUSSBREMSBETÄTIGUNG
REAR BRAKE CONTROL



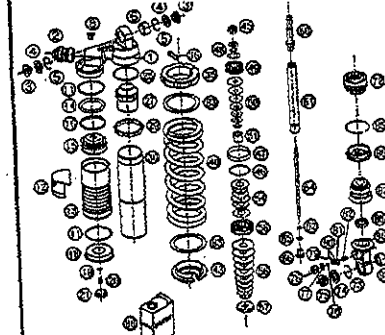
SEITE
Page
10

SCHWINGARM, FEDERBEIN
SWINGARM, SHOCK ABSORBER



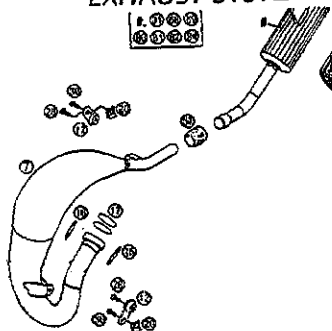
SEITE
Page
11

FEDERBEIN WP ZERLEGT
SHOCK ABSORBER WP DISASSEMBLED



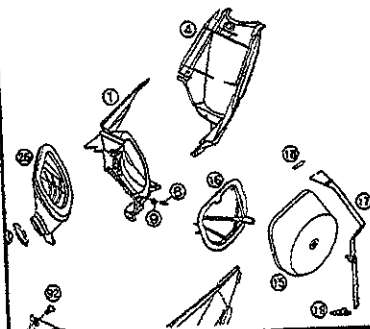
SEITE
Page
12

AUSPUFFANLAGE
EXHAUST SYSTEM



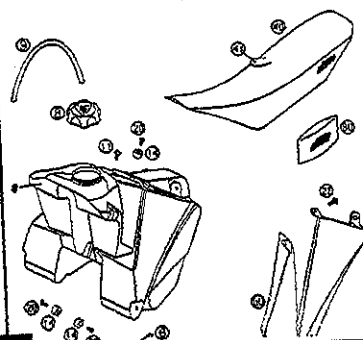
SEITE
Page
14

LUFTFILTERKASTEN
AIR FILTER BOX



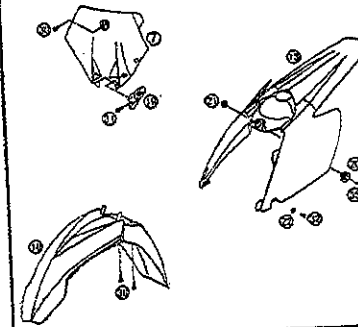
SEITE
Page
15

TANK, SITZBANK, VERKLEIDUNG
TANK, SEAT, COVER



SEITE
Page
16

MASKE, KOTFLÜGEL
MASK, FENDERS



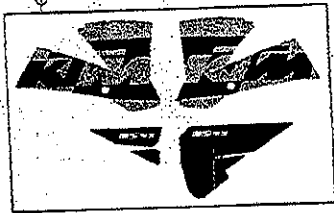
SEITE
Page
17



INHALTSVERZEICHNIS

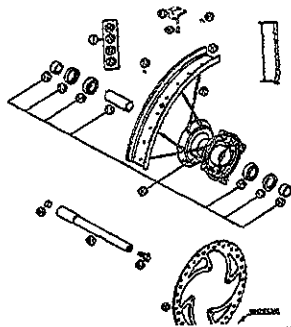
INDEX

DEKOR
DECAL



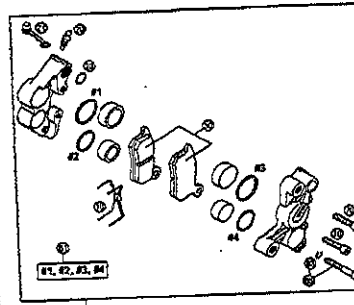
SEITE
Page
18

VORDERRAD
FRONT WHEEL



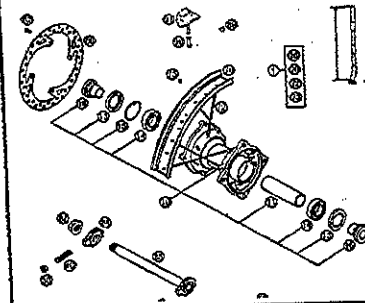
SEITE
Page
19

BREMSZANGE VORNE FORMULA
BRAKE CALIPER FRONT FORMULA



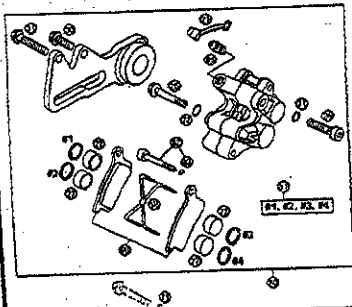
SEITE
Page
20

HINTERRAD
REAR WHEEL



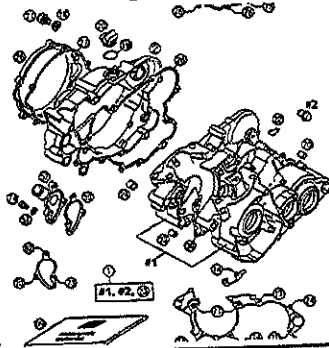
SEITE
Page
21

BREMSZANGE HINTEN FORMULA
BRAKE CALIPER REAR FORMULA



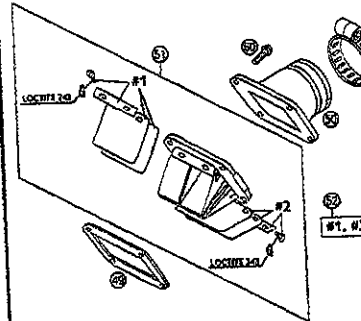
SEITE
Page
22

MOTORGEHÄUSE
ENGINE CASE



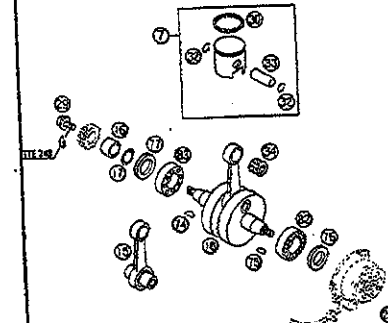
SEITE
Page
23

MEMBRANGEHÄUSE
REED VALVE CASE



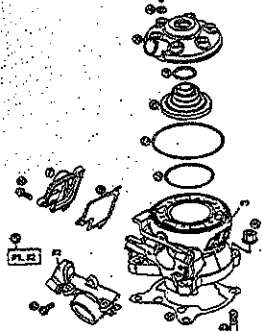
SEITE
Page
24

KURBELWELLE, KOLBEN
CRANKSHAFT, PISTON



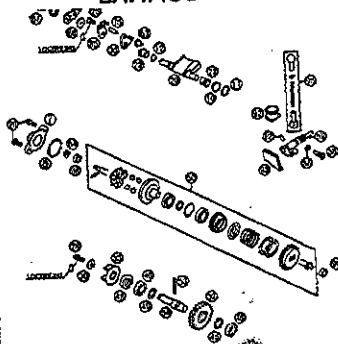
SEITE
Page
25

ZYLINDER
CYLINDER



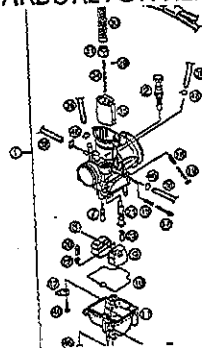
SEITE
Page
26

AUSLASSTEUERUNG
EXHAUST CONTROL



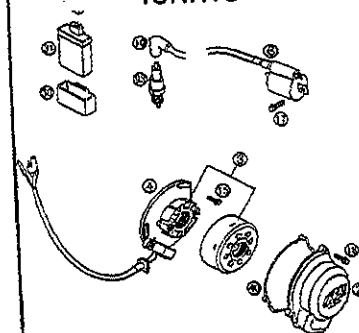
SEITE
Page
27

VERGASER KEIHIN PWK 28
CARBURETOR KEIHIN PWK 28



SEITE
Page
28

ZÜNDANLAGE
IGNITION SYSTEM



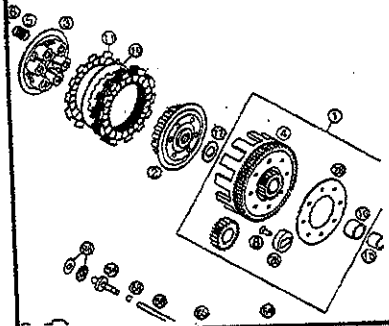
SEITE
Page
29



INHALTSVERZEICHNIS

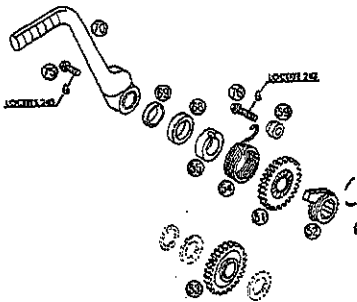
INDEX

KUPPLUNG CLUTCH



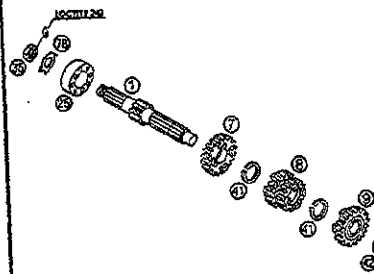
SEITE
Page
30

KICKSTARTER KICKSTARTER



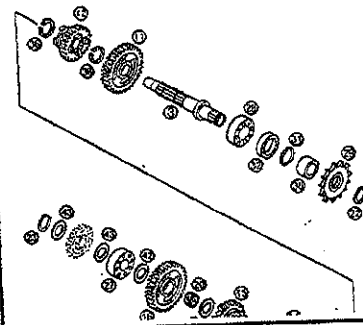
SEITE
Page
31

GETRIEBE I - ANTRIEBSWELLE TRANSMISSION I - MAIN SHAFT



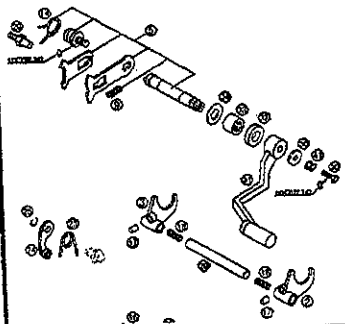
SEITE
Page
32

GETRIEBE II - ABTRIEBSWELLE TRANSMISSION II - COUNTERSHAFT



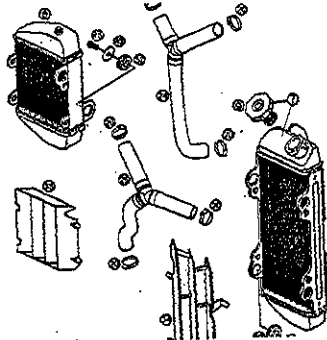
SEITE
Page
33

SCHALTUNG SHIFTING MECHANISM



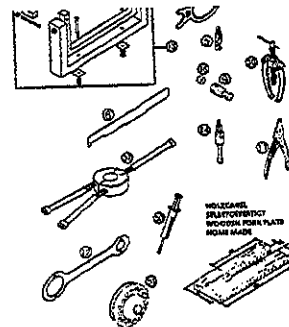
SEITE
Page
34

KÜHLSYSTEM COOLING SYSTEM



SEITE
Page
35

SPEZIALWERKZEUGE SPECIAL TOOLS



SEITE
Page
36

! Die KTM-Sportmotorcycle AG behält sich das Recht vor, Ausrüstung, technische Angaben, Farben, Materialien, Dienstleistungsangebote, Serviceleistungen und ähnliche Dinge ohne vorheriger Ankündigung und ohne Angabe von Gründen zu ändern bzw. ersatzlos zu streichen, sowie die Fertigung eines bestimmten Modells ohne vorherige Ankündigung einzustellen. Für Druckfehler übernehmen wir keine Haftung.

! KTM-Sportmotorcycle AG reserves the right to modify any equipment, technical specifications, colors, materials, services offered and rendered, and the like so as to adapt them to local conditions without previous announcement and without giving reasons, or to cancel any of the above items without substituting them with others. It shall be acceptable to stop manufacturing a certain model without previous announcement. In the event of such modifications, please ask your local KTM dealer for information. We shall not be held liable for any printing errors.

© by KTM-SPORTMOTORCYCLE AG, AUSTRIA Alle Rechte vorbehalten

© by KTM-SPORTMOTORCYCLE AG, AUSTRIA All rights reserved

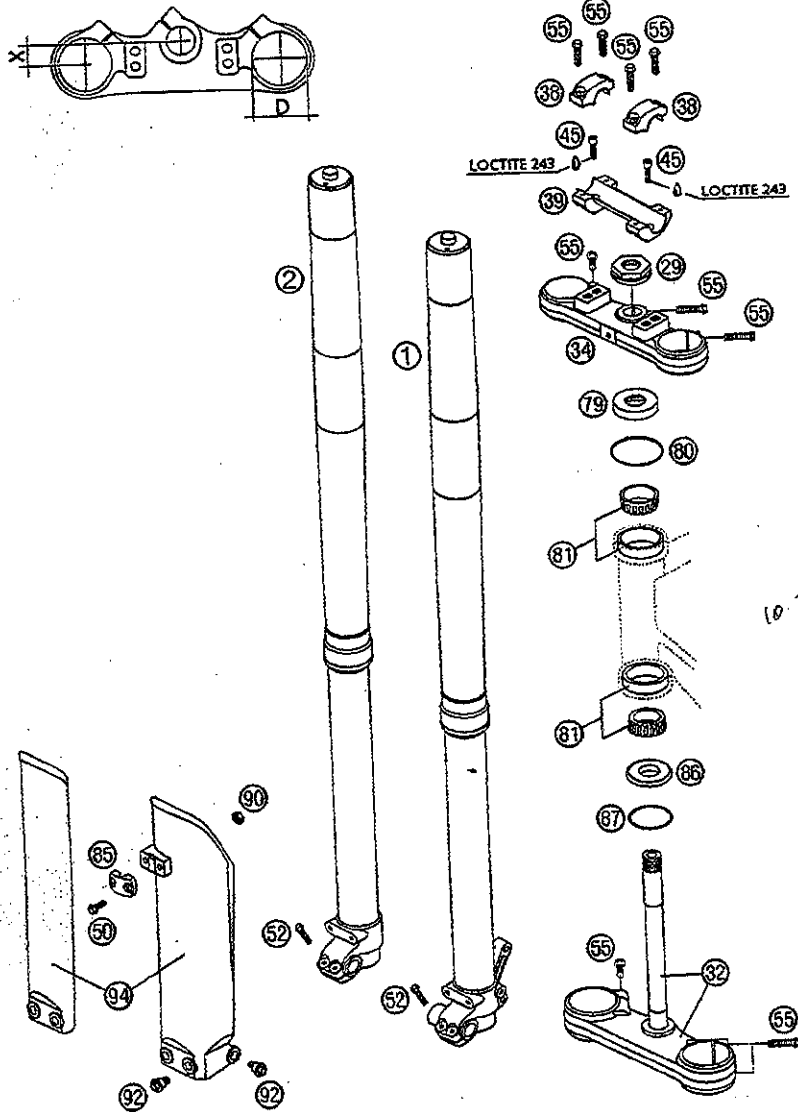


FIG	TEILNR/PARTNR	BEZEICHNUNG	DESCRIPTION	QTY
1*	0518.Y740LS	GABELBEIN LI. 4357 85 SX 04	FORK LEG L/S 4357 85SX 04	1
2*	0518.Y740RS	GABELBEIN RE. 4357 85 SX 04	FORK LEG R/S 4357 85 SX 04	1
29	590.30.029.000	SK-MUTTER M20X1,5 SW=27 RECHTS	HH NUT M20X1,5 WS=27 RIGHT	1
32	470.01.032.014	GABELBRÜCKE UNT. KPL. 85 SX 03	BOT.TRIPLE CLAMP CPL 85 SX 03	1
34	470.01.034.014	GABELBRÜCKE OBEN 85 SX 2003	TOP TRIPLE CLAMP 85 SX 2003	1
38	503.01.038.000	LENKERKLEMMBRÜCKE D=22MM 2001	HANDLEBAR CLAMP D=22MM 2001	2
39	590.01.039.000	LENKERAUFNAHME 22MM 2T 2000	HANDLEBAR SUPPORT 22MM 2T 2000	1
45	0912 100250	ISK.SCHR.DIN6912 M10X25 10.9 S	AH SCREW DIN6912-M10X25,10.9,L	2
50	0015 050163	SK.BUNDSCHRAUBE M 5X16 SW=8	HH COLLAR SCREW M 5X16 WS=8	2
52	0015 060203	SK.BUNDSCHRAUBE M 6X20 SW=8	HH COLLAR SCREW M 6X20 WS=8	4
55	0015 080303	SK.BUNDSCHRAUBE M 8X30 SW=10	HH COLLAR SCREW M 8X30 WS=10	11
79	490.01.086.000	ABDECKKAPPE	COVERING CAP	1
80	0770 021300	O-RING 40,94X2,62 NBR70	O-RING 40,94X2,62 NBR70	1
81	490.01.081.000	KEGELROLLENLAGER 32004X	TAPERED ROLLER BEARING 32004X	2
85	546.01.085.000	BREMSSCHLAUCHKLEMME MARZ. '95	BRAKE HOSE CLAMP MARZOCCHI'95	1
86	460.01.086.000	SCHUTZRING STEUERK. 20,1X39X5	PROTECTION RING 20,1X39X5	1
87	0770 360030	O-RING 36,00X3,00 NBR	O-RING 36,00X3,00 NBR	1
90	0985 050003	SS.MUTTER DIN 985 M5	SELF LOCKING NUT DIN0985-M 5	2
92	590.01.092.050	SONDERSCHRAUBE M6X12,5 SW=8	SPECIAL SCREW M6X12,5 WS=8	6
94	470.01.094.000/30	GABELSCHUTZ LI+RE 85 SX 03	FORK PROTECTOR L/S+R/S 85SX 03	1

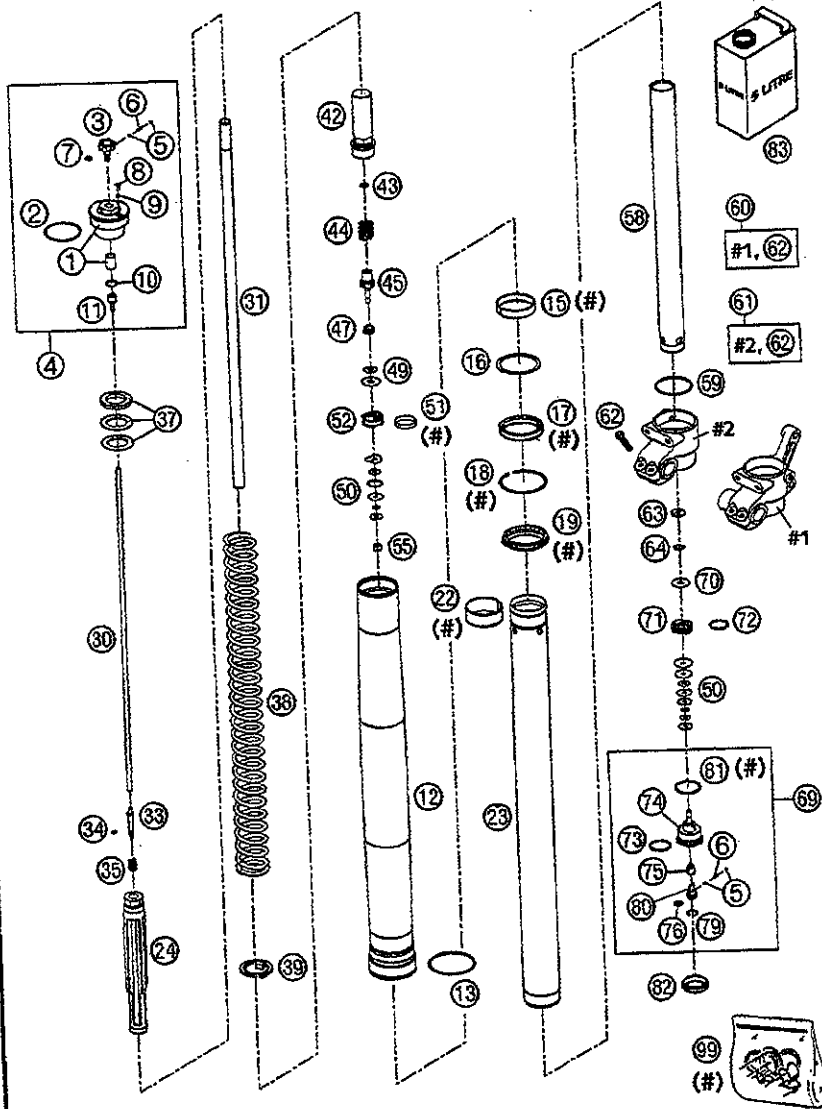


FIG	TEILNR/PARTNR	BEZEICHNUNG	DESCRIPTION	QTY
1*	4357.02165	VERSCHLUSSKAPPE M46X1,5 KPL.	SCREW CAP M46X1,5 CPL.	2
2	4681.1042	O-RING 40,00X2,00 WP	O-RING 40,00X2,00 WP	2
3	4860.0018	EINSTELLKNOPF ZUGSTUFE	KNOB REBOUNG ADJUSTER	2
4	4357.02165	VERSCHLUSSKAPPE M46X1,5 KPL.	SCREW CAP M46X1,5 CPL.	2
5	4054.0603	STAHLKUGEL D=3MM	STEEL BALL D=3MM	8
6	4860.0028	FEDER D=2,9 L=7,9	SPRING D=2,9 L=7,9	4
7	4860.0044	O-RING NBR 6X1,5	O-RING NBR 6X1,5	2
8	4860.0076	ENTLÜFTUNGSSCHRAUBE M4X8	VENT SCREW M4X8	2
9	4860.0009	O-RING NBR 3,7X1,6	O-RING NBR 3,7X1,6	2
10	4860.0043	O-RING NBR 12X1,5	O-RING NBR 12X1,5	2
11	4860.0019	HALTER F. EINSTELLROHR D=4MM	HOLDER F. ADJUSTMENT TUBE D=4MM	2
12	4357.0215	AUSSENROHR L=510 D=49/53 NAT.	OUTER TUBE L=510 D=49/53 NAT.	2
13	4357.0099	FÜHRUNGSRING D=53MM	GUIDING RING D=53MM	2
15	4357.0204	FÜHRUNGSBÜCHSE 43X47X12 DAIDO	DU-BUSH 43X47X12 DAIDO	2
16	4357.0092	TRÄGERRING 45 X 52,5 X 1,5	SUPPORT RING 45 X 52,5 X 1,5	2
17	4357.0201	ÖLDICHTRING 43 X 52,9 X 9,5	OIL SEAL RING 43 X 52,9 X 9,5	2
18	4357.0008	SICHERUNGSRING SB53	LOCK WASHER SB53	2
19	4357.0202	STAUBKAPPE 43 X 53,4 X 11,8	DUST STRIPPER 43 X 53,4 X 11,8	2
22	4357.0203	FÜHRUNGSBÜCHSE 42X44X20	DU-BUS 42X44X20	2
23	4357.0217	GABELHOLM D=43MM L=520MM	INNER TUBE D=43MM L=520MM	2
24	4357.02125	HYDR. STOP L=135MM D=31,9 KPL.	HYDR. STOP L=135MM D=31,9 CPL.	2
30	4860.0310	EINSTELLROHR L=437MM	ADJUSTMENT TUBE L=437MM	2
31	4860.0312	KOLBENSTANGE D=14 L=471 M11X1	PISTON ROD D=14 L=471 M11X1	2
33	4860.0189	NADEL ZUGSTUFE 2003	NEEDLE REBOUND 2003	2
34	4860.0046	O-RING NBR 3X1,5	O-RING NBR 3X1,5	2
35	4860.0033	FEDER ZUGSTUFENNADEL C=4N/MM	SPRING REBOUND NEEDLE C=4N/MM	2
37	4357.0133	VORSPANNBÜCHSE 26X38X2,5	SPACER 26X38X2,5	4
37	4357.0134	VORSPANNBÜCHSE 26X38X5	SPACER 26X38X5	2
37	4357.0135	VORSPANNBÜCHSE 26X38X10	SPACER 26X38X10	4
38	9501.00295	FEDER 2,8 N/MM SET D=4,2MM	SPRING 2,8 N/MM SET D=4,2MM	X
38	9501.00305	FEDER 3,0 N/MM SET D=4,2MM	SPRING 3,0 N/MM SET D=4,2MM	1
38	9501.00315	FEDER 3,2 N/MM SET D=4,2MM	SPRING 3,2 N/MM SET D=4,2MM	X
39	4357.0131	FEDERAUFLAGE 26,2X38,5X3	INTERM. RING 26,2X38,5X3	2
42	4860.02005	SCHRAUBBÜCHSE M29,3X1 L=65 KPL	SCREW SLEEVE M29,3X1 L=65 CPL.	2
43	4860.0239	O-RING NBR 8X1,25	O-RING NBR 8X1,25	2
44	4860.0192	FEDER ZUGSTUFE D=15MM L=34,5MM	REBOUND SPRING D=15MM L=34,5MM	2
45	4860.0203	AUFNAHME FÜR ZUGSTUFE D=3 03	TAB REBOUND D=3 03	2
47	3548.0377	FEDER VENTIL D=0,5	SPRING CHECK VALVE D=0,5	2
49	4860.0062	KONTROLLVENTIL 8X24X0,1	CHECK VALVE 8X24X0,1	8

* = NEUTEIL / NEW PART X = NACH BEDARF / AS REQUIRED



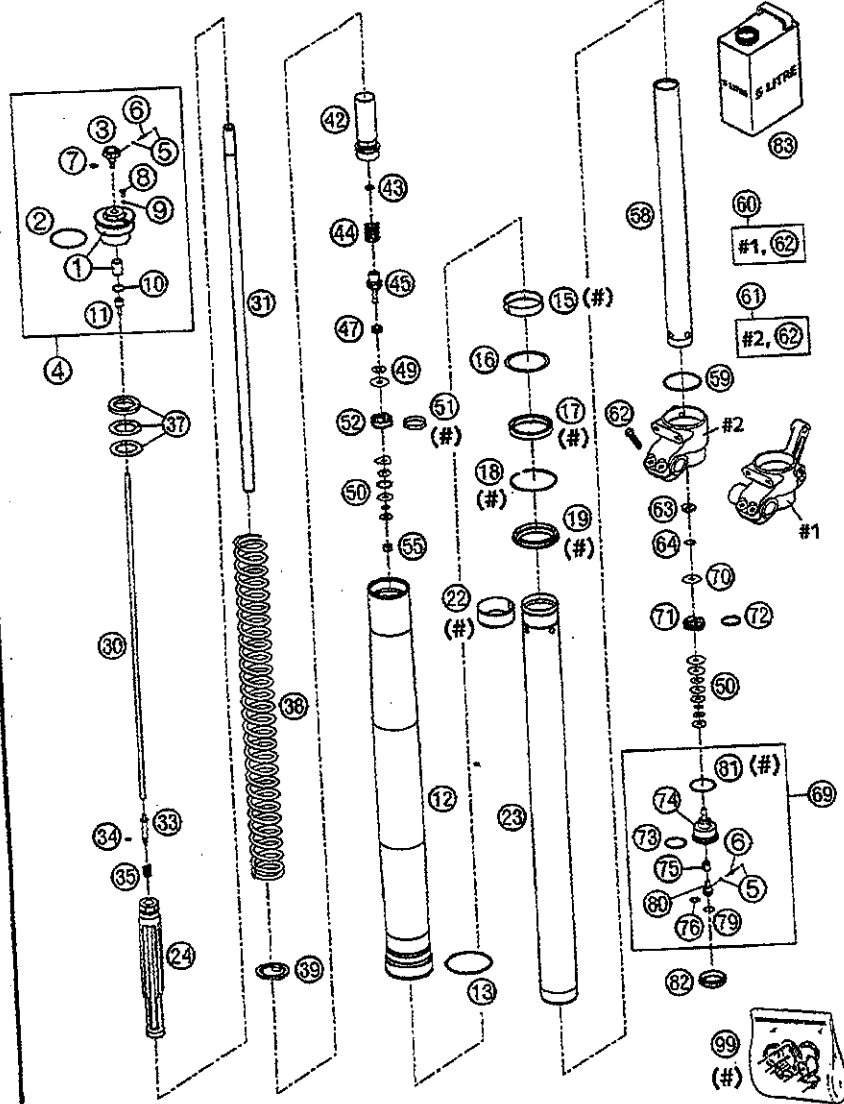
04-470.01.1

GABELBEINE WP USD 43

FORK LEGS WP USD 43

85

2004



04-470.01.1

FIG	TEILNR/PARTNR
49	4860.0062
49	4860.0068
49	4860.0215
49	4860.0216
50	4860.0063
50	4860.0064
50	4860.0065
50	4860.0116
50	4054.0401
50	4054.0402
50	4054.0403
50	4054.0414
50	4054.0415
50	4054.0447
50	4054.0450
51	4860.0060
52	4860.0042
55	4054.0486
58*	4860.0353
59	4357.0023
60	4357.0214
61	4357.0213
62*	0015.060203
63	4860.0163
64	4860.0202
69	4860.0152S1
70	4860.0061
71	4860.0047
72	4681.1499
73	3548.0320
74	4860.0152
75	4860.0190
76	4860.0049
79	4860.0051
80	4860.0034
81	4860.0004
82	4860.0141
83	4860.0211S1
99	R510.

BEZEICHNUNG
KONTROLLVENTIL 8X24X0,1
KONTROLLVENTIL 8X18X0,1
KONTROLLVENTIL 8X20X0,1
KONTROLLVENTIL 8X22X0,1
SCHEIBE 6X24X0,1
SCHEIBE 6X22X0,1
SCHEIBE 6X20X0,1
SCHEIBE 6X24X0,1 DELTA
SCHEIBE 6X14X0,1
SCHEIBE 6X16X0,1
SCHEIBE 6X18X0,1
SCHEIBE 6X16X0,25
SCHEIBE 6X18X0,25
SCHEIBE 6X10X0,3
SCHEIBE 6X9,5X0,3
KOLBENRING 5X1X84
KOLBEN ZUGSTUFE D=27,7
MUTTER M6X0,5 ZUGSTUFE
ROHR 29,3X1X370 D=8,5MM ALU
O-RING NBR 41X2
GABELFAUST LINKS 85 SX 03
GABELFAUST RECHTS 85 SX 03
SK.BUNDSCHRAUBE M 6X20 SW=8
MUTTER VENTIL M6X0,5 D=2
FEDER VENTIL D=0,7
AUFNAHME FÜR DRUCKSTUFE KPL.03
KONTROLLVENTIL 8X24X0,4
KOLBEN DRUCKSTUFE D=27,9
O-RING NBR 21X2
O-RING NBR 24X2
AUFNAHME FÜR DRUCKSTUFE
NADEL DRUCKSTUFE 2003
O-RING NBR 8X2
SICHERUNGSRING RB12
EINSTELLSCHRAUBE DRUCKSTUFE
CU-SCHEIBE 29,5X33,5X1
GUMMIKAPPE D=35MM
GABELÖL SAE 5
REPSATZ DICHT. 4357 MXMA 03

DESCRIPTION	QTY
CHECK VALVE 8X24X0,1	8
CHECK VALVE 8X18X0,1	2
CHECK VALVE 8X20X0,1	2
CHECK VALVE 8X22X0,1	2
SHIM 6X24X0,1	X
SHIM 6X22X0,1	X
SHIM 6X20X0,1	X
SHIM 6X24X0,1 DELTA	X
SHIM 6X14X0,1	X
SHIM 6X16X0,1	X
SHIM 6X18X0,1	X
SHIM 6X16X0,25	X
SHIM 6X18X0,25	X
SHIM 6X10X0,3	X
SHIM 6X9,5X0,3	X
PISTON RING 5X1X84	2
PISTON REBOUND D=27,7	2
NUT M6X0,5 REBOUND	2
TUBE 29,3X1X370 D=8,5MM ALU	2
O-RING NBR 41X2	2
AXLE CLAMP L/S 85 SX 03	1
AXLE CLAMP R/S 85 SX 03	1
HH COLLAR SCREW M 6X20 WS=8	4
CHECK VALVE NUT M6X0,5 D=2	2
SPRING CHECK VALVE D=0,7	2
TAP COMPRESSION CPL. 03	2
CHECK VALVE 8X24X0,4	2
PISTON COMPRESSION D=27,9	2
O-RING NBR 21X2	2
O-RING NBR 24X2	2
TAP COMPRESSION	2
NEEDLE COMPRESSION 2003	2
O-RING NBR 8X2	2
LOCK WASHER RB12	2
COMPRESSION ADJ. SCREW	2
COPPER WASHER 29,5X33,5X1	2
RUBBER CAP D=35MM	2
FORK OIL SAE 5	1
REPAIR-KIT GASKET 4357 MXMA 03	1

* = NEUTEL / NEW PART X = NACH BEDARF / AS REQUIRED



03-470.02.0

LENKER, ARMATUREN

HANDLEBAR, CONTROLS

85

2004

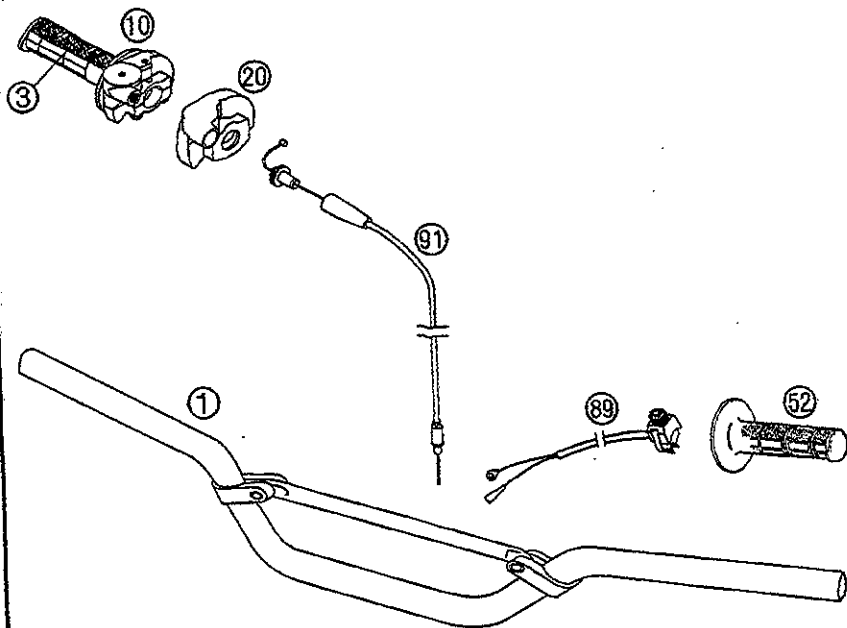
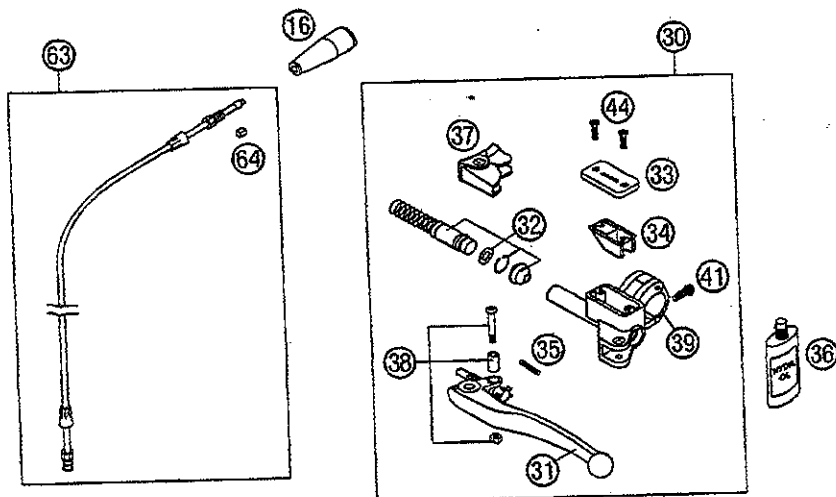


FIG	TEILNR/PARTNR	BEZEICHNUNG
1	470.02.001.000	LENKER D=22MM 85 SX 2003
3	502.02.003.000	DREHGRIFFÜBERZUG DOMINO SCHW.
10	503.02.010.000	GASDREHGRIFF KPL. OHNE SEIL'97
16	540.02.016.000	SCHUTZKAPPE
20	503.02.020.000	SCHUTZKAPPE DOMINO '97
30	503.02.030.200	GEBERZYLINDER KPL. 9,5MM 04
31	546.02.031.000	KUPPLUNGHEBEL KURZ KPL. 2003
31	590.02.031.000	KUPPLUNGHEBEL LANG KPL. 2003
32	590.02.032.000	REP.SATZ KOLBEN 9,5MM RAC.2000
33	503.02.033.100	DECKEL HYD.KUPPLUNG 2T 2000
34	503.02.034.000	GUMMIBALG FÜR RESERVOIR '98
35	590.02.035.000	FEDER FÜR KUPPLUNGHEBEL 03
36	503.02.036.000	ÖL FÜR HYD.KUPPLUNG 50ML
37	503.02.037.000	SCHUTZKAPPE FÜR HEBELGELENK'98
38	503.02.038.000	HEBELSCHRAUBE KPL. 125-200 '98
39	503.02.030.150	KLEMMSCHELLE M.SPANNSTIFT 2000
41	0015 060203	SK.BUNDSCHRAUBE M 6X20 SW=8
44	0965 040123	SENKSCHRAUBE DIN0965-M 4X12
52	502.02.052.000	FESTGRIF DOMINO SCHWARZ '95
63	461.32.063.000	LEITUNGSKIT F.HYDR.KUPPL. 65SX
64	503.32.063.050	SCHNEIDRING FÜR HYDR.LEITUNG
89	503.11.089.200	KURZSCHLUSSCHALTER 02
91	503.02.091.000	GASSEIL 125-380 DOMINO/KEIHIN

DESCRIPTION	QTY
HANDLEBAR D=22MM 85 SX 2003	1
TWIST GRIP COVER DOMINO BLACK	1
THR.TWIST CRIP CPL. W.O. C.'97	1
PROTECTION CAP	1
PROTECTION COVER '97	1
MASTER CYLINDER CPL. 9,5MM 04	1
CLUTCH LEVER SHORT CPL. 2003	1
CLUTCH LEVER LONG CPL. 2003	X
REP.KIT PISTON 9,5MM RAC. 2000	1
COVER HYD.CLUTCH 2T 2000	1
RUBBER FOR RESERVOIR '98	1
SPRING FOR CLUTCH LEVER 03	1
OIL FOR HYD.CLUTCH 50ML	1
PROTECT.CAP FOR LEVER PERCH'98	1
LEVER SCREW CPL 125-200 '98	1
CLAMP WITH PIN 2000	1
HH COLLAR SCREW M 6X20 WS=8	1
FLAT HEAD SCREW DIN0965-M 4X12	2
FIXED GRIP DOMINO BLACK '95	1
PIPE KIT FOR HYDR.CLUTCH 65 SX	1
SELF CUTTING RING HYDR.PIPE	1
SHORT CIRCUIT BUTTON 02	1
THROTTLE C. 125-380 DOM./KEIH.	1



03-470.02.0

7

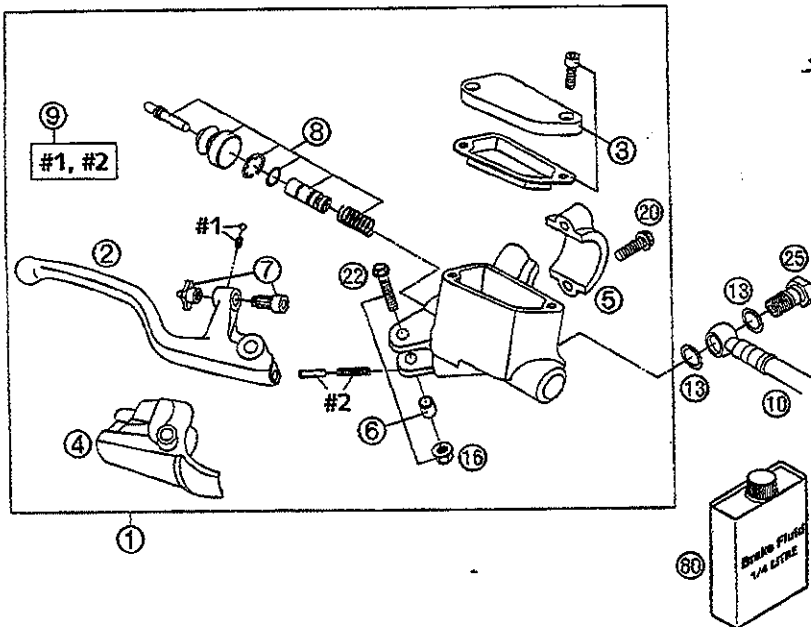
* = NEUTEIL / NEW PART

X = NACH BEDARF / AS REQUIRED

MOTOTECH
MOTORCYCLE TECHNOLOGY

C222 3166

FIG	TEILNR/PARTNR	BEZEICHNUNG	DESCRIPTION	QTY
1	470.13.001.000	HANDBREMSZYLINDER KPL.85 SX 03	HAND BRAKE CYL. CPL. 85 SX 03	1
2	470.13.002.000	BREMSHEBEL LOSE 85 SX 2003	BRAKE LEVER LOOSE 85 SX 2003	1
3	470.13.003.000	ZYLINDERDECKEL KPL. VORNE 2003	CYLINDER COVER CPL. FRONT 2003	1
4	470.13.004.000	SCHUTZKAPPE 85 SX 2003	PROTECTION COVER 85 SX 2003	1
5	470.13.005.000	SCHELLE FÜR BREMSZYLINDER 2003	CLAMP FOR BRAKE CYLINDER 2003	1
6	470.13.006.000	SCHRAUBE+BÜCHSE+MUTTER 03	SCREW+BUSHING+NUT 03	1
7	470.13.007.000	EINSTELLSCHRAUBE KPL. 85 SX 03	ADJUSTING SCREW CPL. 85 SX 03	1
8	470.13.008.000	REPSATZ KOLBEN VORNE 85 SX 03	REP.SET PISTON FRONT 85 SX 03	1
9	470.13.009.000	KUGEL+FEDERN+FEDERFÜHRUNG 03	BALL+SPRING+SPRING GUIDE 03	1
10	461210101000	BREMSSCHLAUCH VORNE 65 SX 2004	BRAKE HOSE FRONT 65 SX 2004	1
13	0770 080019	O-RING 8,00X1,00 EPDM	O-RING 8,00X1,00 EPDM	1
16*	565.09.064.100	STOVER-FLANSCHMUTTER M6 10.9	SELF LOCKING NUT M6 10.9	2
20	0015 060203	SK.BUNDSCHRAUBE M 6X20 SW=8	HH COLLAR SCREW M 6X20 WS=8	1
22*	0015 060303	SK.BUNDSCHRAUBE M 6X30 SW=8	HH COLLAR SCREW M 6X30 WS=8	1
25	470.13.025.000	HOHLSCHRAUBE BREMSZYLINDER 03	HOLLOW SCREW BRAKE CYLINDER 03	1
80	306054	BREMSSFLÜSSIGKEIT DOT 5.1	BRAKE FLUID DOT 5.1	1



10 * NEW PART NUMBER.
470 13 010 000

MOTOTECH
MOTORCYCLE TECHNOLOGY

FIG TEILNR/PARTNR

BEZEICHNUNG

DESCRIPTION

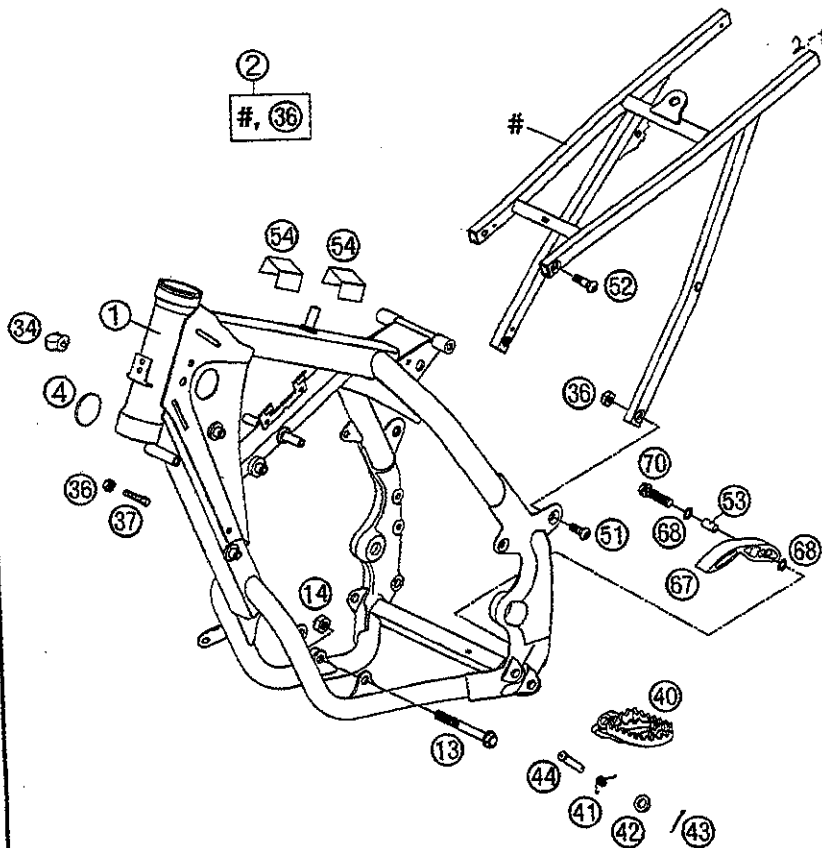
QTY

1	470.03.001.000
2	470.03.002.044
4	546.06.004.000
13	470.03.013.000
14	543.10.086.100
34*	581.11.076.000
36	0934 080003
37	590.01.037.000
40	590.03.040.050
40	590.03.041.050
41	546.03.041.000
42	0125 100003
43	0094 032253
44	548.03.044.000
51	546.10.052.000
52	545.10.052.100
53	511.03.053.051
54	587.11.054.050
67*	511.03.053.000
68	360.03.014.000
70	0015 080303

RAHMEN 85 SX	W3* 03
AUSLEGER 85 SX (B3)	03
VERSCHLUSSKAPPE 37MM	
MOTORTRAGSCHRAUBE 85 SX	
SS.MUTTER M10 CU	SW=14
KABELHALTER KHS NR. 150-47610	
SK.MUTTER DIN 934 M8	
ANSCHLAGSCHRAUBE M8X26 SW=10	
FUSSRASTE LI. EXC SILBER	2000
FUSSRASTE RE. EXC SILBER	2000
FUSSRASTENFEDER LINKS & RECHTS	
UNTERLEGSCHIBE DIN 125 A 10,5	
SPLINT DIN0094-3,2X25 STAHL	
BOLZEN FÜR FUSSRASTE	03
KETTENRADSCHR. M8X20 ISK	SW=6
KETTENRADSCHR. M8X26 ISK	SW=6
BÜCHSE 8,2X10X20	
METAMOLL F. BATTERIEHALTEBÜGEL	
KETTENGLEITSTÜCK UNTEN '97	
SCHNORR-SICHERUNGSSCHIBE 8MM	
SK.BUNDSCHRAUBE M 8X30	SW=10

FRAME 85 SX	2003
SUB FRAME 85 SX (B3)	03
PLUG 37MM	
ENGINE BRACKET SCREW 85 SX	
SELF LOCKING NUT M10 CU	WS=14
CABLE SUPPORT KHS NR.150-47610	
HEXAGON NUT DIN0934-M 8	
SPECIAL SCREW M8X26 WS=10	
FOOT PED L/S EXC SILVER	2000
FOOT PED R/S EXC SILVER	2000
FOOTREST SPRING L/S & R/S	
WASHER DIN0125-A10,5	
PIN DIN0094-3,2X25 STEEL	
BOLT FOR FOOT PED	03
SPROCKET SCREW-AH M8X20 WS=6	
SPROCKET SCREW-AH M8X26 WS=6	
BUSHING 8,2X10X20	
METAMOLL FOR BATTERY BRACKET	
CHAIN SLIDING PIECE BELOW '97	
LOCK WASHER 8MM	
HH COLLAR SCREW, M 8X30	WS=10

1
1
2
2
2
2
2
4
2
1
1
2
2
2
2
2
2
2
1
2
2
1
1
2
2
1



* = NEUTEIL / NEW PART

X = NACH BEDARF / AS REQUIRED

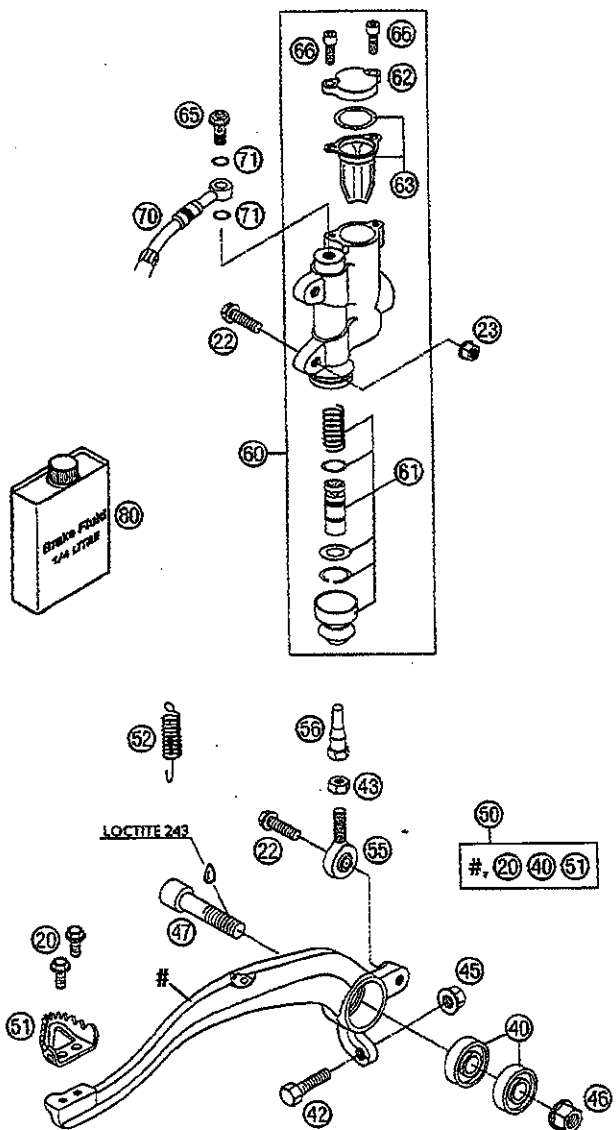


FIG	TEILNR/PARTNR	BEZEICHNUNG	DESCRIPTION	QTY
	20	0015 050123	SK.BUNDSCHRAUBE M 5X12 WS=8	2
	22	0015 060203	SK.BUNDSCHRAUBE M 6X20 WS=8	3
	23	565.09.064.100	STOVER-FLANSCHMUTTER M6 10.9	2
	40	0625 060001	RILLENKUGELLAGER 6000/C3	2
	42	590.01.037.000	ANSCHLAGSCHRAUBE M8X26 WS=10	1
	43	0934 060003	SK.MUTTER DIN 934 M6	1
	45	460.30.045.000	BUNDMUTTER M8 WS=10	1
	46	490.09.082.000	STOVERFLANSCHMUTTER M10 FK10	1
	47	0912 100303	ISK.SCHRAUBE DIN 912 M10X30	1
	50	470.13.050.044	FUSSBREMSHEBEL KPL 85 SX 03	1
	51	548.13.051.000	AUFTRITT FÜR BREMSHEBEL	1
	52	546.03.062.000	RÜCKZUGFEDER FÜR BREMSHEBEL	1
	55	548.13.055.000	GELENKKOPF KA6 03	1
	56	470.13.056.000	DRUCKSTANGE 85 SX 2003	1
	60	470.13.060.000	FUSSBREMSZYL. HI. KPL. D=11 03	1
1, 2	60*	470.13.060.100	FUSSBREMSZYL. HI. KPL. D=12 04	X
	61	470.13.061.000	REP. SATZ KOLBEN HI. D=11 2003	1
2, 4	61*	470.13.061.100	REP. SATZ KOLBEN HI. D=12 2004	X
	62	470.13.062.000	ZYLINDERDECKEL HINTEN 85 SX 03	1
	63	470.13.063.000	DICHTUNG ZYLINDERDECKEL HI. 03	1
	65	470.13.025.000	HOHLSCHRAUBE BREMSZYLINDER 03	1
	66	0912 040103	ISK.SCHRAUBE DIN0912-M 4X10	2
	70	470.13.070.000	BREMSSCHLAUCH HINTEN 85 SX 03	1
	71	0770 080019	O-RING 8,00X1,00 EPDM	2
	80	306054	BREMSFLÜSSIGKEIT DOT 5.1	1

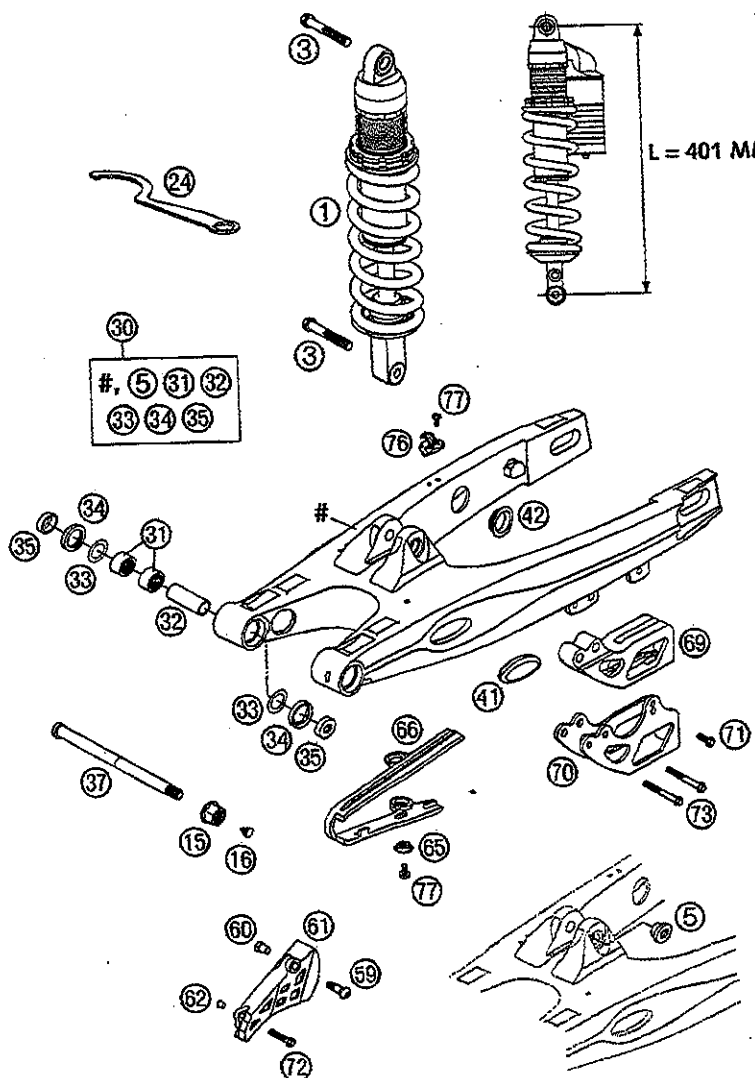


FIG	TEILNR/PARTNR
	1518.Y706
3	0015 120556
5	5018.0105
15	546.03.015.000
16	544.03.135.000
24*	460.12.024.000
	470.04.030.144
31	590.04.031.000
32	502.03.081.700
33	590.33.080.000
34	0760 253270
35	546.03.090.000
37	470.04.037.000
41	584.04.041.000
42	584.04.041.100
59	545.10.052.100
60	470.30.060.051
61	470.07.061.000
62	583.14.060.050
65	722.10.079.000
66	584.04.066.000
69	546.07.066.100
70	546.07.070.144
71	0015 060163
72	0015 060303
73	0015 060503
76	546.11.076.100
77	0009 050103

BEZEICHNUNG	DESCRIPTION	QTY
MONOSHOCK 4618 PDS 85 SX 04	MONOSHOCK 4618 PDS 85 SX 04	1
SK.BUNDSCHRAUBE M12X55 SW=13	HH COLLAR SCREW M12X55 WS=13	2
GEWINDEBÜCHSE M12 PDS	THREADED BUSH M12 PDS	1
STOPPMUTTER M14X1,5 SW=19	SELF LOCKING NUT M14X1,5 WS=19	1
VERSCHLUSSPFROPFEN SFL10	PLASTIC CAP SFL10	1
HAKENSCHLÜSSEL FÜR FEDERBEIN	HOOK WRENCH FOR SHOCK ABSORBER	1
SCHWINGE 85SX KPL. 2004	SWINGARM 85SX CPL. 2004	1
NADELHÜLSE HK2012V	NEEDLE BUSH HK2012V	4
LAGERHÜLSE 15X20X38,75	BUSHING SLEEVE 15X20X38,75	2
SCHEIBE 20X32X1	SHIM 20X32X1	2
WELLENDICHTRING 25X32X7	SHAFT SEAL RING 25X32X7	4
TASSE.FÜR.WELLENDICHTR.15X25X9	BUCKET F.SHAFTSEALRING 15X25X9	4
SCHWINGARMBOLZEN 85 SX 2003	SWINGARM BOLT 85 SX 2003	1
VERSCHLUSSKAPPE SCHWINGE SM 03	CLOSING COVER SWINGARM SM 03	2
VERSCHLUSSKAPPE RUND 03	CLOSING COVER ROUND 03	4
KETTENRADSCHR. M8X26 ISK SW=6	SPROCKET SCREW-AH M8X26 WS=6	1
GEWINDEBÜCHSE FÜR KETTENSCHUTZ	THREADED BUSH FOR CHAIN GUARD	1
KETTENSCHUTZ 85 SX 2003	CHAIN GUARD 85 SX 2003	1
DISTANZBÜCHSE F.TACHOHALTERUNG	SPACER BUSH. F. SPEEDOMET.BRA.	1
STÜTZSCHALE	BUCKET	2
KETTENGLEITSCHUTZ SM 03	CHAIN SLIDING GUARD SM 03	1
KETTENFÜHRUNG HINTEN '94	CHAIN GUIDE REAR '94	1
HALTEBLECH KPL.	RETAINING PLATE CPL.	1
SK.BUNDSCHRAUBE M 6X16 SW=8	HH COLLAR SCREW M 6X16 WS=8	1
SK.BUNDSCHRAUBE M 6X30 SW=8	HH COLLAR SCREW M 6X30 WS=8	1
SK.BUNDSCHRAUBE M 6X50 SW=8	HH COLLAR SCREW M 6X50 WS=8	2
HALTESCHELLE FÜR BREMSSCHL.'96	RETAIN.CLAMP FOR BRAKE HOSE'96	2
GEW.FURCHSCHRAUBE M 5,0X10	SPECIAL SCREW M 5,0X10	4

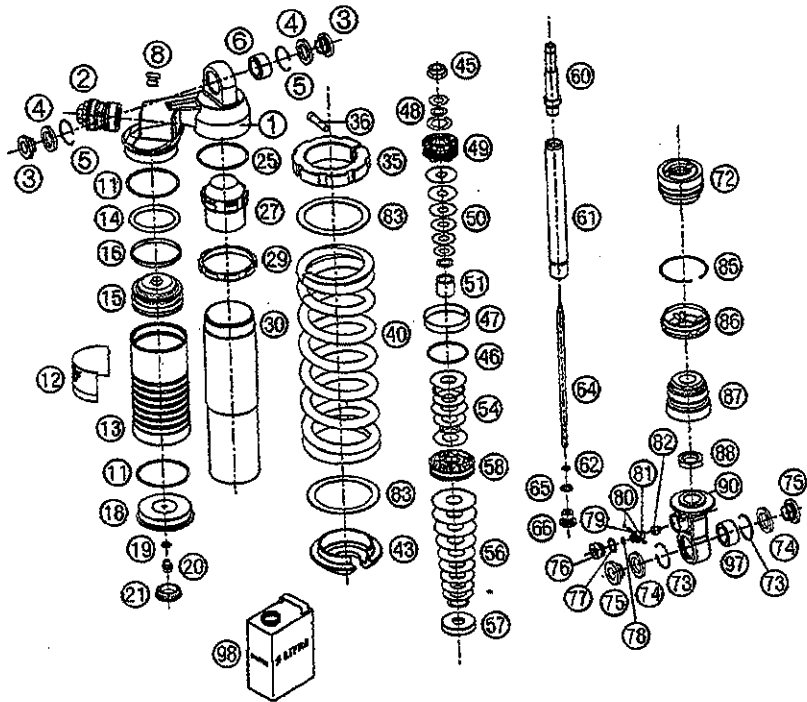


FIG	TEILNR/PARTNR	BEZEICHNUNG	DESCRIPTION	QTY
1*	4618.0348	FEDERBEINGEH. OBEN H40 135GR.	SHOCK ABSORBER TOP H40 135DEG.	1
2	5018.021354	DCC-DRUCKSTUFENREGUL. KPL. 03	DCC-COMPR.DAMP.CONTROL CPL 03	1
3	4618.0007	DISTANZBÜCHSE KGW 12X24	ADAPTOR BUSH KGW 12X24	4
4	4618.0003	DICHTRING KGW D=25	OIL SEAL KGW D=25	4
5	5018.0168	SCHEIBE KGW D=25	WASHER KGW D=25	4
6*	5018.0005	LAGER KGW 1525 HD	BUSHING KGW 1525 HD	2
8	5018.0095	ENTLÜFTUNGSSCHRAUBE R 1/8	BLEED PLUG R 1/8	1
11	4618.0017	O-RING NBR 50X2	O-RING NBR 50X2	2
12*	5200.0014	AUFKLEBER WP 35X55	STICKER WP 35X55	1
13	4618.0319	RESERVOIRSCHRAUBE L=113,5 D=52	RESERVOIR SCREW L=113,5 D=52	1
14*	4618.0014	O-RING VITON 41X5	O-RING VITON 41X5	1
15	4618.0002	TRENNKOLBEN D=52; H=32	SEPARATION PISTON D=52; H=32	1
16	4618.0015	KOLBENRING 3,9X1,5X156	PISTON RING 3,9X1,5X156	1
18	5018.0344	RESERVOIRKAPPE D=58	RESERVOIR CAP D=58	1
19	4681.0893	O-RING NBR 5,28X1,78	O-RING NBR 5,28X1,78	1
20	3612.0151	VERSCHLUSSSCHRAUBE M5X6	SCREW PLUG M5X6	1
21	4681.1208	GUMMIKAPPE „NICHT ÖFFNEN“	RUBBER CAP „DO NOT OPEN“	1
25	4681.0016	O-RING NBR 48X2	O-RING NBR 48X2	1
27*	4618.0340	HÜLSE D=48	SLEEVE D=48	1
29*	4618.0352	SICHERUNGSSCHEIBE M52X1,5	LOCK WASHER M52X1,5	1
30*	4618.0345	ROHR M52X1,5	TUBE M52X1,5	1
35*	4618.0353	EINSTELLRING M52X1,5	SPRING RETAINER M52X1,5	1
36*	4618.0354	ISK.SCHRAUBE M5X25	AH SCREW M5X25	1
40	9101.0240	FEDER (59) 215 35 N/MM D=9,25	SPRING (59) 215 35 N/MM D=9,25	X
40	9101.0161	FEDER (59) 215 40 N/MM D=9,5	SPRING (59) 215 40 N/MM D=9,5	1
40	9101.0201	FEDER (59) 215 45 N/MM D=10	SPRING (59) 215 45 N/MM D=10	X
43*	4618.0349	FEDERRING H=15 D=28	SPRING WASHER H=15 D=28	1
45*	4618.0356	KOLBENSTANGENMUTTER M10X1	PISTON ROD NUT M10X1	1
46	4681.0035	O-RING VITON 37,82X1,78	O-RING VITON 37,82X1,78	1
47	4681.1206	KOLBENRING 8X46	PISTON RING 8X46	1
48	3612.0349	SCHEIBE 10X19X0,30	SHIM 10X19X0,30	1
48	5018.0032	SCHEIBE 16X25X0,25	BACKPLATE 15X25X0,25	1
48	5018.0395	RING 10X16X1	RING 10X16X1	1
49	1446.0016	KOLBEN + KOLBENFEDER	PISTON + PISTON SPRING	1
50*	3612.0312	SCHEIBE 10X16X0,30	BACKPLATE 10X16X0,30	1
50*	3612.0334	SCHEIBE 10X21X0,20	SHIM 10X21X0,20	1
50*	3612.0335	SCHEIBE 10X23X0,20	SHIM 10X23X0,20	1
50*	3612.0336	SCHEIBE 10X25X0,20	SHIM 10X25X0,20	1
50*	3612.0337	SCHEIBE 10X27X0,20	SHIM 10X27X0,20	3
50*	3612.0338	SCHEIBE 10X29X0,20	SHIM 10X29X0,20	1
50*	3612.0339	SCHEIBE 10X31X0,20	SHIM 10X31X0,20	1
51*	4618.0339	VERBUNDBÜCHSE 17X12X18	SEPARATION BUSH 17X12X18	1
54*	4681.0505	SCHEIBE 12X36X0,25	SHIM 12X36X0,25	2
54	4681.0519	SCHEIBE 12X28X0,15	SHIM 12X28X0,15	1

* = NEUTEIL / NEW PART

X = NACH BEDARF / AS REQUIRED

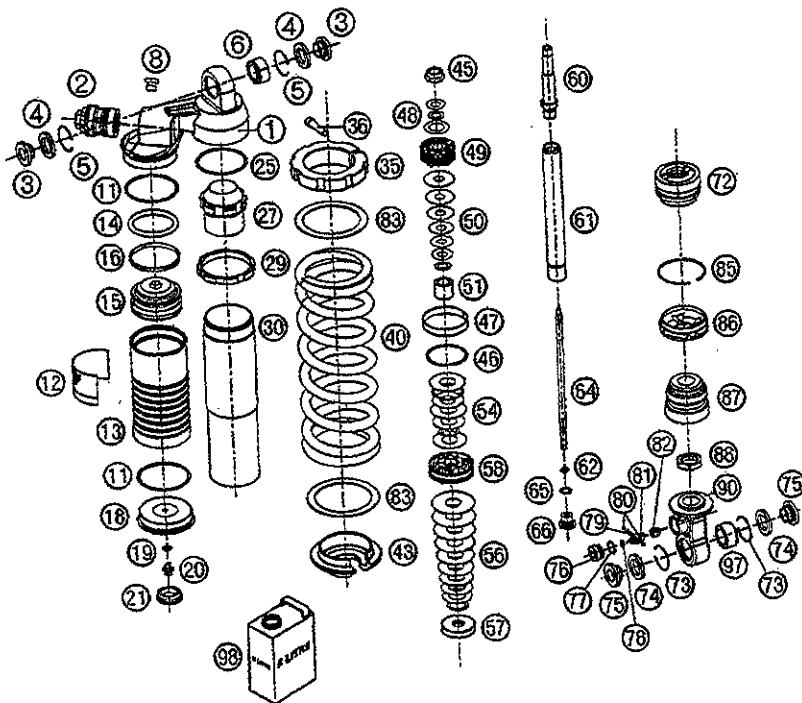


FIG	TEILNR/PARTNR	BEZEICHNUNG	DESCRIPTION	QTY
54	4681.0495	SCHEIBE 12X34X0,20	SHIM 12X34X0,20	1
54	4681.0494	SCHEIBE 12X32X0,20	SHIM 12X32X0,20	1
54	4681.0493	SCHEIBE 12X30X0,20	SHIM 12X30X0,20	1
54	4681.0492	SCHEIBE 12X28X0,20	SHIM 12X28X0,20	1
54	4681.0637	SCHEIBE 12X17X0,30	BACKPLATE 12X17X0,30	1
56	4681.0491	SCHEIBE 12X26X0,20	SHIM 12X26X0,20	1
56	4681.0492	SCHEIBE 12X28X0,20	SHIM 12X28X0,20	1
56	4681.0493	SCHEIBE 12X30X0,20	SHIM 12X30X0,20	1
56	4681.0494	SCHEIBE 12X32X0,20	SHIM 12X32X0,20	1
56	4681.0520	SCHEIBE 12X30X0,15	SHIM 12X30X0,15	1
56	4681.0522	SCHEIBE 12X34X0,15	SHIM 12X34X0,15	1
56	4681.0523	SCHEIBE 12X36X0,15	SHIM 12X36X0,15	1
56	4681.0524	SCHEIBE 12X38X0,15	SHIM 12X38X0,15	1
56	4681.0525	SCHEIBE 12X40X0,15	SHIM 12X40X0,15	7
56	4681.0637	SCHEIBE 12X17X0,30	BACKPLATE 12X17X0,30	1
56	4618.0179	SCHEIBE ZUGSTUFE H=0	REBOUND DISC H=0	X
57	4618.0337	SCHEIBE ZUGSTUFE H=4	REBOUND DISC H=4	1
58	4618.0047	KOLBEN 5X4,5X/6X6	PISTON 5X4,5X/6X6	1
60*	4618.0343	GEWINDEKOLBENSTANGE D=13,5	TAP PISTON ROD D=13,5	1
61*	4618.0342	ACHSE D=18 LC=159	SPINDEL D=18 LC=159	1
62*	5018.0397	O-RING VITON 5X1,5	O-RING VITON 5X1,5	1
64*	4618.0346	ZUGSTUFENNADEL L=169	NEEDLE REBOUND L=169	1
65*	4618.0018	O-RING NBR 7,5X2	O-RING NBR 7,5X2	1
66*	4618.0350	NADELFÜHRUNG	NEEDLE GUIDE	1
72*	4618.03415	ADAPTER KPL. D=46 H=28 D=38	ADAPTOR CPL. D=46 H=28 D=38	1
73*	5018.0168	SCHEIBE KGW D=25	WASHER KGW D=25	2
74*	4618.0003	DICHTRING KGW D=25	OIL SEAL KGW D=25	2
75*	4618.0007	DISTANZBÜCHSE KGW 12X24	ADAPTOR BUSH KGW 12X24	2
76*	4618.0355	RESERVOIRKAPPE M16X1	RESERVOIR CAP M16X1	1
77*	4618.0013	O-RING NBR 12X1	O-RING NBR 12X1	1
78*	5018.0222	O-RING NBR 4X1,5	O-RING NBR 4X1,5	1
79*	4860.0028	FEDER D=2,9 L=7,9	SPRING D=2,9 L=7,9	1
80*	4054.0603	STAHLKUGEL D=3MM	STEEL BALL D=3MM	2
81*	4618.0006	EINSTELLSCHRAUBE L=15,5	ADJUSTING SCREW L=15,5	1
82*	4618.0016	EINSTELLADAPTER ZUGSTUFE	ADJUSTING ADAPTOR REBOUND	1
83*	5018.0410	SCHEIBE-FEDER D=58	INTERM. RING D=58	2
85	4681.0010	SPRENGRING 49X1,5	CIRCLIP 49X1,5	1
86*	4618.0338	DECKEL D=46 H=9,5	CAP D=46 H=9,5	1
87	5018.0276	GUMMIPUFFER WP60 D=18-26	BUMP RUBBER WP60 D=18-26	1
88*	5018.0283	KONTERMUTTER M18X1 H=5	CONTRA NUT M18X1 H=5	1
90*	4618.0347	FEDERBEINGEH. UNTEN KGW L=54,5	SHOCK ABSORBER BOT. KGW L=54,5	1
97*	5018.0005	LAGER KGW 1525 HD	BUSHING KGW 1525 HD	1
98	5018.034251	DÄMPFERÖL 5 LT	SHOCK ABSORBER FLUID 5 LT 2003	1

* = NEUTEIL / NEW PART

X = NACH BEDARF / AS REQUIRED

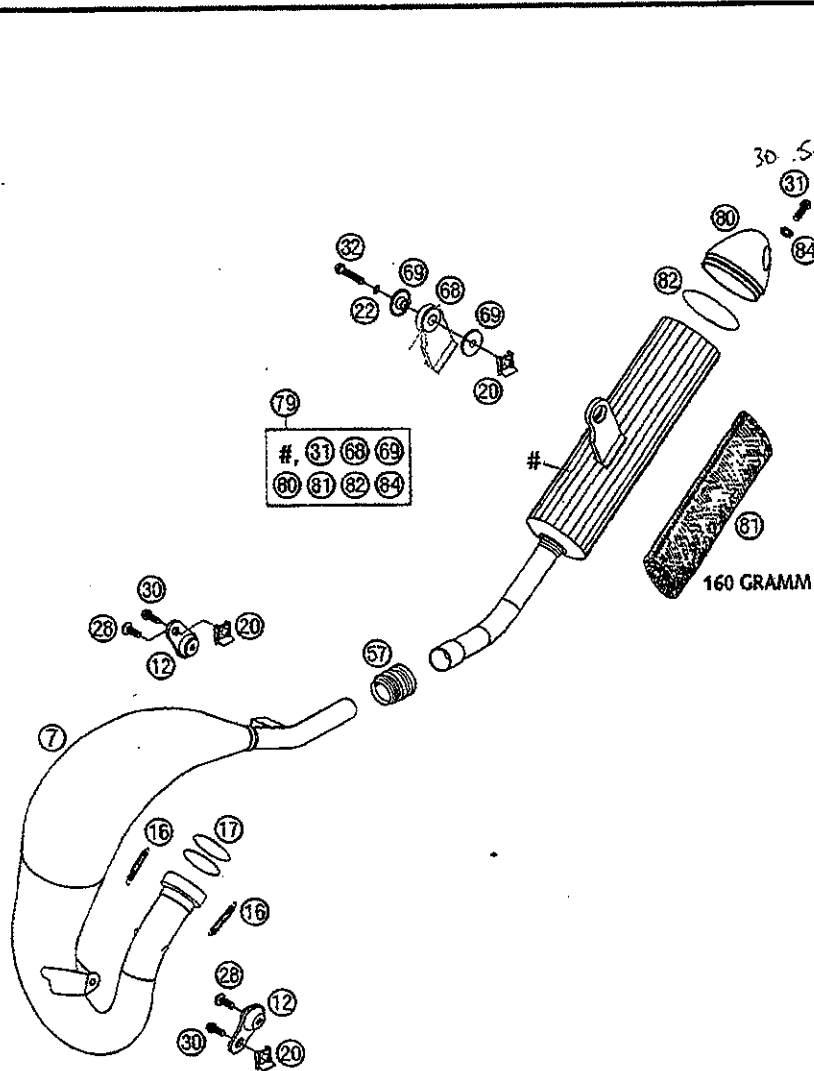


FIG	TEILNR/PARTNR	BEZEICHNUNG	DESCRIPTION	QTY
7	470.05.007.000	AUSPUFF 85 SX 2003	EXHAUST PIPE 85 SX 2003	1
12	503.05.012.000	SCHWINGELEMENT FÜR AUSPUFF	SWINGELEMENT FOR EXHAUST PIPE	2
16	503.05.016.000	ZUGFEDER L=55MM ÖSEN BEWEGLICH	TEN.SPRING L=55MM EY.MOVEABLE	2
17*	0770 380030	O-RING 38,00X3,00 VITON	O-RING 38,00X3,00 VITON	2
20	546.03.048.100	MEHRBEREICHSBLECHMUTTER M6	RANGE CHANGE METAL NUT M6	3
22	0137 060003	FEDERSCHEIBE DIN 137 B 6	SPRING WASHER DIN0137-B 6	1
28*	0014 060103	SK.BUNDSCHRAUBE M 6X10 SW=8	HH COLLAR SCREW M 6X10 WS=8	2
30	0015 060163	SK.BUNDSCHRAUBE M 6X16 SW=8	HH COLLAR SCREW M 6X16 WS=8	2
31	0015 060203	SK.BUNDSCHRAUBE M 6X20 SW=8	HH COLLAR SCREW M 6X20 WS=8	2
32	0015 060303	SK.BUNDSCHRAUBE M 6X30 SW=8	HH COLLAR SCREW M 6X30 WS=8	1
57	546.05.057.000	GUMMIMUFFE D=21/23MM '93	RUBBER SLEEVE D=21MM/23MM '93	1
68	546.05.068.000	DÄMPFUNGELEMENT SCHWARZ	EXHAUST BRACKET RUBBER BLACK	1
69	546.05.069.000	BÜCHSE 7,5X12X28X7,8 '96	BUSHING 7,5X12X28X7,8 '96	2
79	470.05.079.000	ENDDÄMPFER 85 SX 2003	SILENCER 85 SX 2003	1
80	503.05.079.169	ENDDÄMPFER ENDKAPPE SX HINTEN	SILENCER ENDCAP SX REAR	1
81	503.05.079.160	GLASFASERGARN 160 GRAMM	STUFFING YARN 160 GRAM	1
82	0770 055020	O-RING 55,00X2,00 NBR70	O-RING 55,00X2,00 NBR70	2
84	502.33.041.000	NORDLOCKSCHEIBEN M6 (PAAR) DAC	PAIR OF WASHERS M 6 NORDLOCK	2

FIG	TEILNR/PARTNR	BEZEICHNUNG	DESCRIPTION	QTY
1	470.06.001.051	FILTERWAND 85 SX 2003	FILTER WALL 85 SX 2003	1
3	470.06.003.000	LUFTFILTERDECKEL 85 SX 2003	FILTER BOX COVER 85 SX 2003	1
4	470.06.001.052	KASTENHINTERTEIL 85 SX 2003	REAR PART FILTER BOX 85 SX 03	1
7	548.06.008.051	SCHNELLVERSCHLUSS-NIPPEL 03	QUICK RELEASE-NIPPLE 03	2
8	548.06.008.052	BLINDNIETE 3,2MM ALU 03	RIVET 3,2MM ALU 03	4
9	548.06.008.050	SCHNELLVERSCHLUSS-FEDERLASCHE	QUICK RELEASE-SPRING HANGER	2
10	460.06.010.000	SPRITZSCHUTZ 60/65 SX '98	SPLASH PROTECTOR 60/65 SX '98	1
11	470.06.010.050	VERSCHRAUBUNG SPRITZSCHUTZ	SCREW CONNECTION SPLASH SHIELD	1
15	503.06.015.000	LUFTFILTER 125-380 '98	AIR FILTER 125-380 '98	1
16	503.06.016.000	FILTERTRÄGER 125-380 '98	FILTER CARRIER 125-380 '98	1
17	503.06.017.000	FILTERHALTEBÜGEL KPL. 2TAKT'98	FILTER SUPPORT CPL.2-STROKE'98	1
18	503.06.018.000	FILTERTRÄGERHÜLSE 125-380 '98	FILTER SUPPORT BUSH 125-380'98	1
19	470.06.019.000	BEFEST.BLECH F. FILTERBÜGEL VO	FASTEN. DEVICE FILTER SUPPORT	1
20	0017 060303	SONDERSCHRAUBE T60 6X30 SW=6	SPECIAL SCREW T60 6X30 WS=6	1
26	470.06.026.000	VERGASERMANSCHETTE 85 SX 2003	CARB. CONNECTING BOOT 85 SX 03	1
58	460.05.058.000	SCHLAUCHBINDER 40-60MM	HOSE CLAMP 40-60MM	1
92	590.01.092.050	SONDERSCHRAUBE M6X12,5 SW=8	SPECIAL SCREW M6X12,5 WS=8	2

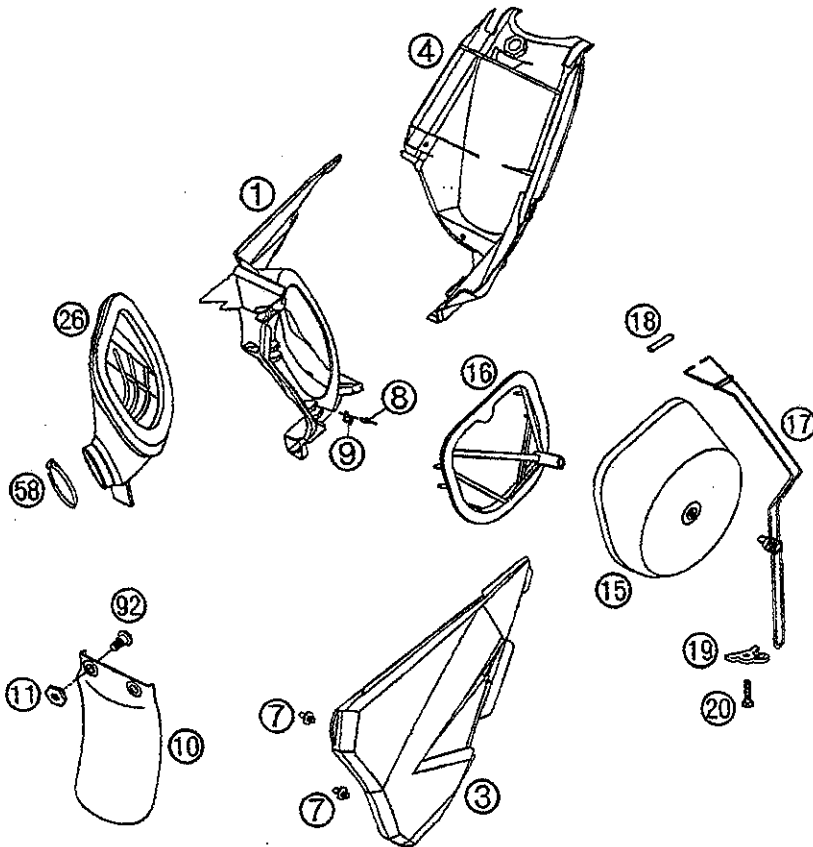


FIG	TEILNR/PARTNR	BEZEICHNUNG	DESCRIPTION	QTY	
	5	503.07.005.000	BENZINHAHN MIKUNI ON/OFF 2001	GAS COCK MIKUNI ON/OFF 2001	1
	6	0770 130023	O-RING 13,00X2,30	O-RING 13,00X2,30	1
	8	490.07.008.044	TANKVERSCHLUSS KPL. KLEIN	FILLER CAP CPL. SMALL	1
	9*	503.07.000.300	ENTLÜFTUNGSSCHLAUCH 6X9X300	BREATHER TUBE 6X9X300	1
	11	503.07.011.000	SCHRAUBE SITZBANKB. D=6X23/18	SCREW SEAT FASTENING D=6X23/18	1
	13	470.07.013.000/04	BENZINTANK 85 SX 2003	FUEL TANK 85 SX 2003	1
	14	503.07.014.000	TANKROLLE 12X26X12 '98	TANK ROLLER 12X26X12 '98	3
	17*	450.31.005.000	YDNAC-KLAMMER BENZINSCHL.(8MM)	YDNAC-CLAMP FUEL HOSE (8MM)	2
	18	583.07.016.001	BENZINSCHL. VITON 6X1,5 PER/M	FUEL HOSE VITON 6X1,5 PER/M	0,27
	20	0015 060123	SK.BUNDSCHRAUBE M 6X12 SW=8	HH COLLAR SCREW M 6X12 WS=8	3
	22	0017 060203	SONDERSCHRAUBE T60 6X20 SW=6	SPECIAL SCREW T60 6X20 WS=6	10
	40	470.07.040.000	SITZBANK 85 SX 2003	SEAT 85 SX 2003	1
	41	470.07.040.050	SITZBANKÜBERZUG 85 SX 2003	SEAT COVER 85 SX 2003	1
	50	470.08.050.000/04	SPOILER LINKS 85 SX 2003	SPOILER L/S 85 SX 2003	1
	50	470.08.051.000/04	SPOILER RECHTS 85 SX 2003	SPOILER R/S 85 SX 2003	1
	80	502.12.100.100	BORDWERKZEUG 125-380 ORANGE'97	TOOL SET 125-380 ORANGE '97	1

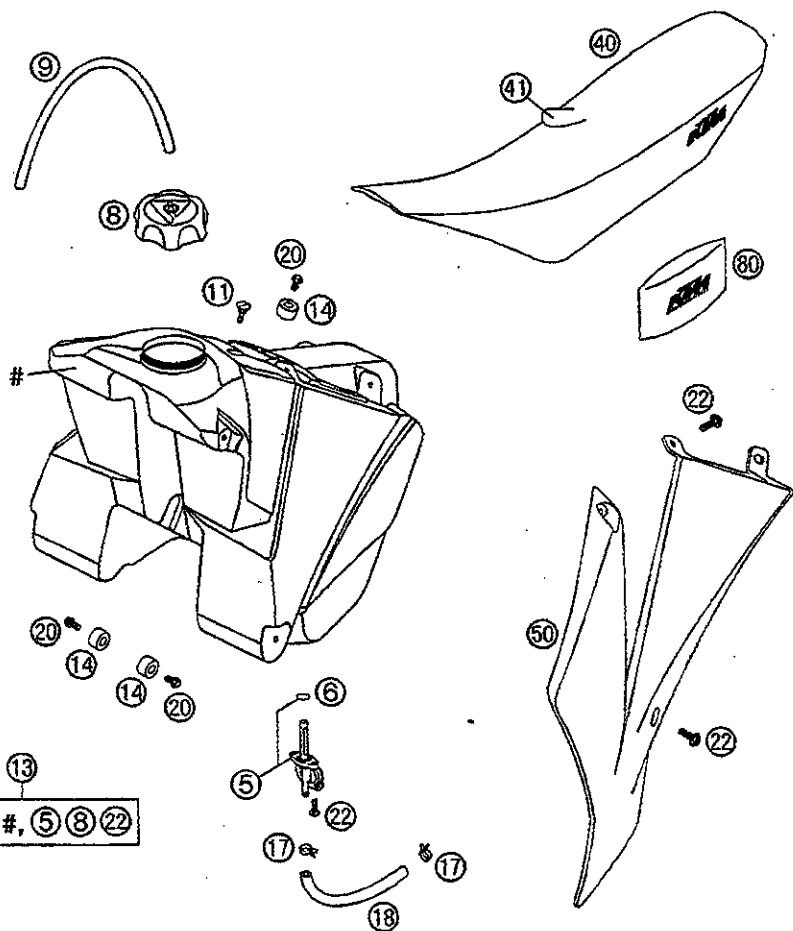
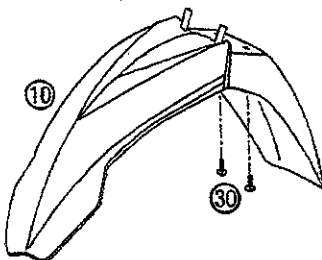
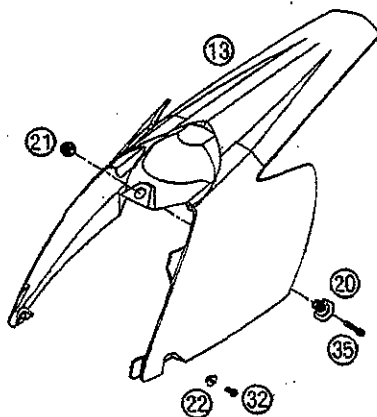
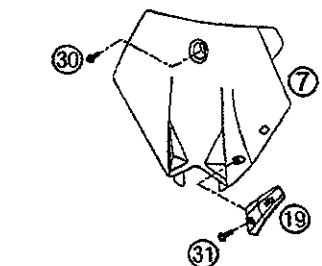


FIG	TEILNR/PARTNR	BEZEICHNUNG	DESCRIPTION	QTY
7	470.08.007.000/04	STARTNUMMERTAFEL 85 SX 2003	NUMBER PLATE 85 SX 2003	1
10	470.08.010.000/04	KOTFLÜGEL VORNE 85 SX 2003	FENDER FRONT 85 SX 2003	1
13	470.08.013.000/04	HECKTEIL 85 SX 2003	REAR PART 85 SX 2003	1
19	548.08.019.000	BREMSSCHLAUCHFÜHRUNG SCHW. 03	BRAKE HOSE GUIDE BLACK 03	1
20	548.07.048.000	BÜCHSE F. SITZBANKBEFESTIG. 03	BUSHING FOR SEAT FASTENING 03	1
21	503.14.057.050	BUNDMUTTER M12X1/SW17 H=5MM	COLLAR NUT M12X1/WS17 H=5MM	1
22	503.08.052.000	BUNDBÜCHSE 6X11X16X5 MM	BUSH FOR SPOILER 6X11X16X5 MM	2
30	0014 060153	SK.BUNDSCHRAUBE M 6X15 SW=8	HH COLLAR SCREW M 6X15 WS=8	5
31	0017 060204	SONDERSCHR. T60 6X20 ALU SW=6	SPECIAL SCR. T60 6X20 ALU WS=6	1
32	0015 060163	SK.BUNDSCHRAUBE M 6X16 SW=8	HH COLLAR SCREW M 6X16 WS=8	2
35	0015 060253	SK.BUNDSCHRAUBE M 6X25 SW=8	HH COLLAR SCREW M 6X25 WS=8	1



MOTOTECH
MOTORCYCLE TECHNOLOGY

FIG	TEILNR/PARTNR	BEZEICHNUNG	DESCRIPTION	QTY
10-20 1*	470.08.099.100	DEKORSATZ 85 SX 2004	DECAL SET 85 SX 2004	1

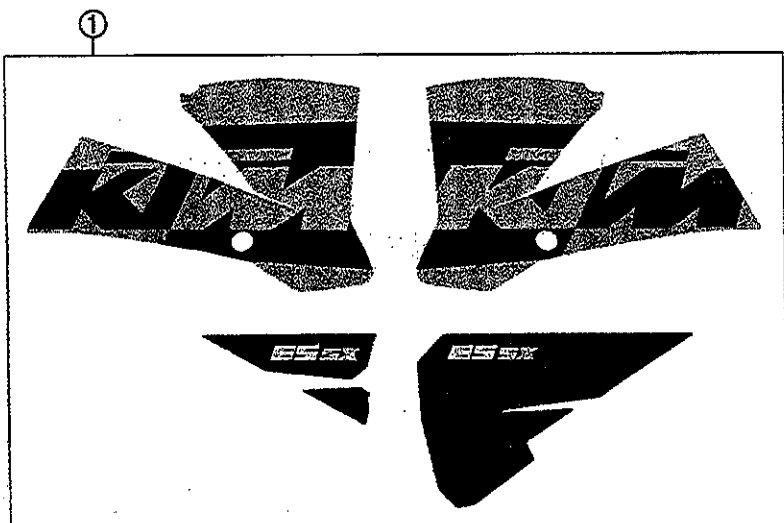
**MOTOTECH**
MOTORCYCLE TECHNOLOGY

FIG	TEILNR/PARTNR	BEZEICHNUNG	DESCRIPTION	QTY
1	470.09.001.044	VORDERRAD ET 85 SX 17" 03	FRONT WHEEL SP 85 SX 17" 03	1
1	470.09.001.144	VORDERRAD ET 85 SX 19" 03	FRONT WHEEL SP 85 SX 19" 03	1
10	470.09.010.044/96	VORDERRADNABE KPL. 85 SX 03	FRONT WHEEL HUB CPL 85 SX 03	1
11	470.09.011.000	LAGERDISTANZROHR VORNE 03	BEARING SPACER TUBE 85 SX 03	1
12	470.09.012.000	DISTANZBÜCHSE 85 SX 03	SPACER BUSHING 85 SX 03	2
13	0760 253570	WELLENDICHTRING 25X35X7 BTSL	SHAFT SEAL RING 25X35X7 BTSL	2
14	0625 060037	RILLENKUGEL. 6003-2RSH/C3HMTF	GR.BALL BEAR. 6003-2RSH/C3HMTF	2
55	590.09.062.013	SONDERSCHRAUBE M6X13 SW=8 10.9	SPECIAL SCREW M6X13 WS=8 10.9	4
60	470.09.060.000	BREMSSCHEIBE VORNE D=220MM 03	BRAKE DISC FRONT D=220MM 03	1
70	470.09.070.000	FELGE VORNE AL4 17X1,40-32 03	RIM FRONT AL4 17X1,40-32 03	1
70	470.09.070.100	FELGE VORNE AL4 19X1,60-32 03	RIM FRONT AL4 19X1,60-32 03	X
72	470.09.072.186	SPEICHE VO. 17" 4/3,5/4-186 03	SPOKE FRONT 17" 4/3,5/4-186 03	32
72	470.09.072.210	SPEICHE VO. 19" 4/3,5/4-210 03	SPOKE FRONT 19" 4/3,5/4-210 03	X
73	503.09.072.000	SPEICHENNIPPEL M4,5X0,75 8X21	SPOKE NIPPLE M4,5X0,75 8X21	32
81	470.09.081.000	STECKACHSE VORNE 85 SX 03	AXLE FRONT 85 SX 03	1
83	490.32.011.000	SK.BUNDSCHRAUBE M10X20 SW=17	HH COLLAR SCREW M10X20 WS=17	1
86	550.09.086.000	VERSCHLUSSPFROPFEN SFL13	PLUG SFL13	1
89	550.03.135.000	BLINDSTOPFEN FÜR FELGE	PLUG FOR RIM	X
90	503.10.090.050	MÜTTER FÜR REIFENHALTER '96	NUT FOR WHEEL HOLDER '96	X
91	510.09.100.100	REIFENHALTER VM1 (1,60") NUR FÜR 19" RAD	RIM LOCK VM1 (1,60") ONLY FOR 19" WHEEL	X

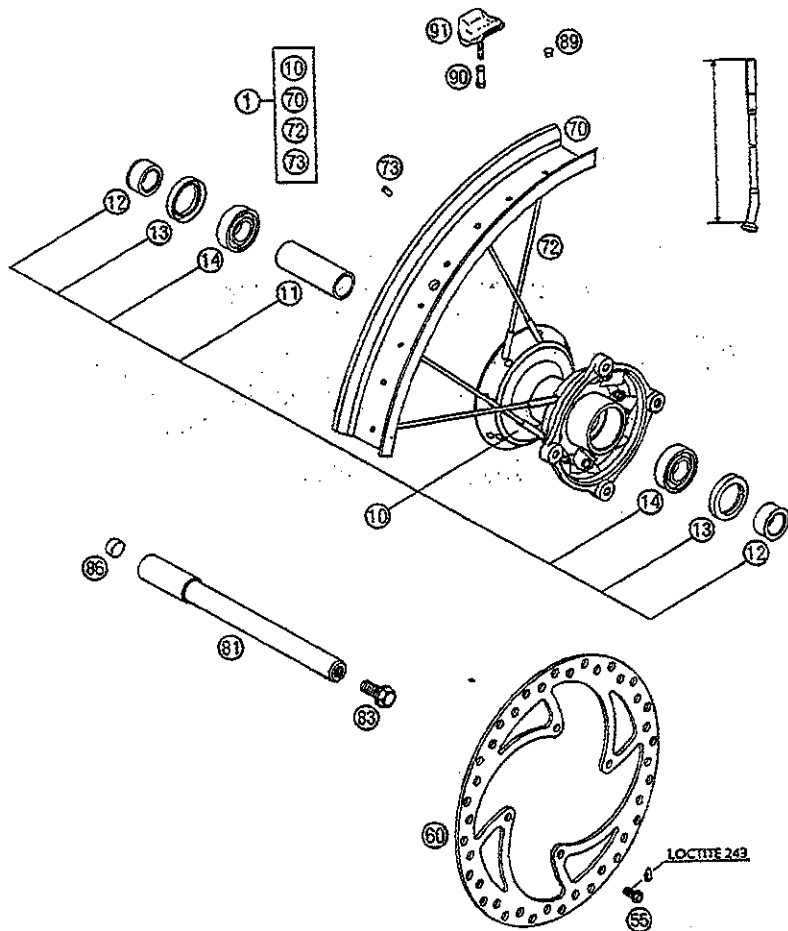
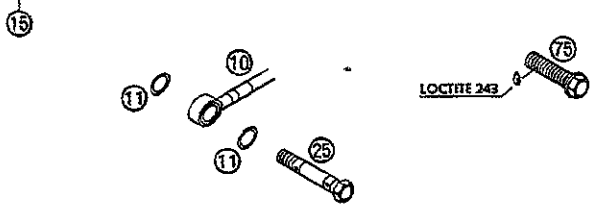
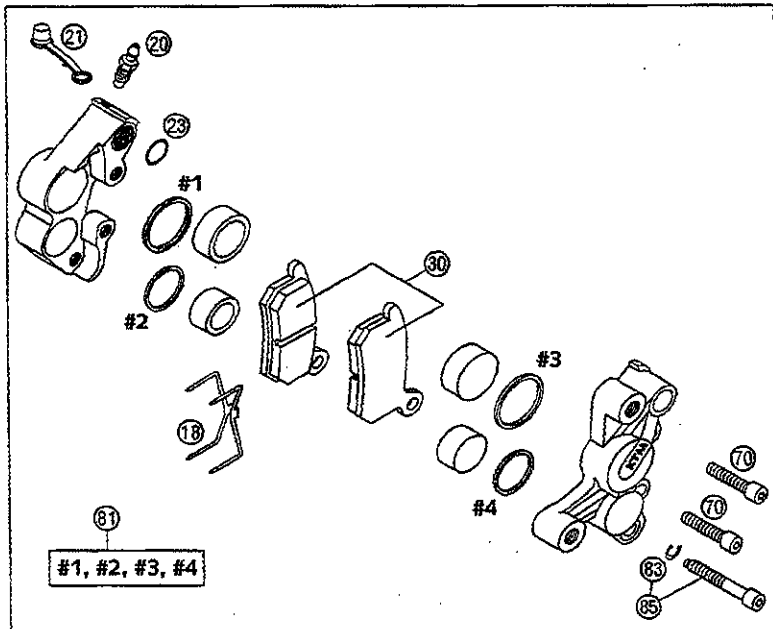


FIG	TEILNR/PARTNR	BEZEICHNUNG	DESCRIPTION	QTY
10	470.13.010.000	BREMSSCHLAUCH VORNE 85 SX 03	BRAKE HOSE FRONT 85 SX 03	1
11	0770 080019	O-RING 8,00X1,00 EPDM	O-RING 8,00X1,00 EPDM	2
15	470.13.015.000	BREMSZANGE VORNE KPL. 85 SX 03	BRAKE CALIPER FR. CPL.85 SX 03	1
18	461.13.018.000	HALTEFEDER 65 SX	RETAINING SPRING 65 SX	1
20	470.13.020.000	ENTLÜFTUNGSSCHRAUBE M6	BLEEDER SCREW M6	1
21	470.13.021.000	KAPPE FÜR ENTLÜFTUNGSSCHRAUBE	CAP FOR BLEEDER SCREW	1
23	0770 100019	O-RING 10X1 EPDM	O-RING 10X1 EPDM	1
25	470.13.125.000	HOHLSCHRAUBE M8X38,8	HOLLOW SCREW M8X38,8	1
30	461.13.030.000	GARN. BREMSKLÖTZE VORNE 2002	BRAKE PAD SET FRONT 2002	1
70	0912 060283	ISK.SCHRAUBE DIN0912-M 6X28	AH SCREW DIN0912-M 6X28	2
75	0015 080303	SK.BUNDSCHRAUBE M 8X30 SW=10	HH COLLAR SCREW M 8X30 WS=10	2
81	461.13.019.000	REP. SATZ DICHRING 2002	REPAIR KIT SEAL RING 2002	1
83	0799 040009	SICH.SCHEIBE DIN6799-RA 4,0	TAB WASHER DIN6799-RA 4,0	1
85	461.13.125.000	ISK.SCHRAUBE + S-RING 2002	AH SCREW + CIRCLIP 2002	1



MOTOTECH
MOTORCYCLE TECHNOLOGY

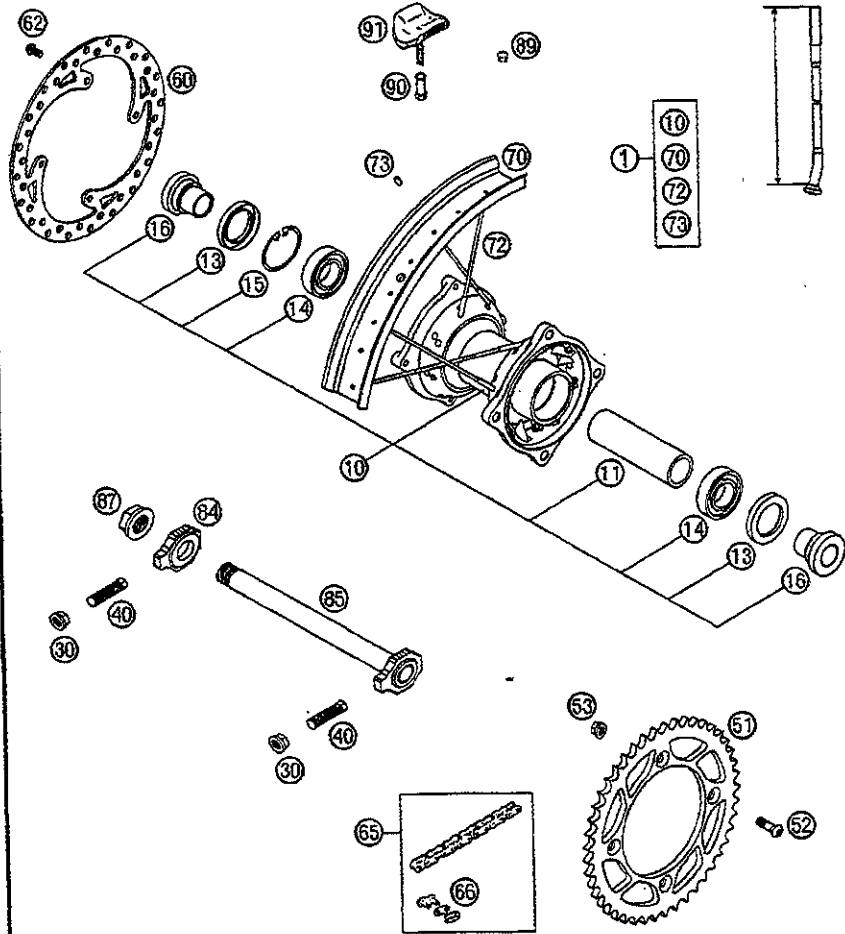


FIG	TEILNR/PARTNR	BEZEICHNUNG	DESCRIPTION	QTY
1	470.10.001.044	HINTERRAD ET 85 SX 14" 03	REAR WHEEL SP 85 SX 14" 03	1
1	470.10.001.144	HINTERRAD ET 85 SX 15" 03	REAR WHEEL SP 85 SX 15" 03	X
1	470.10.001.244	HINTERRAD ET 85 SX 16" 03	REAR WHEEL SP 85 SX 16" 03	1
10	470.10.010.044/96	HINTERRADNABE KPL. 85 SX 03	REAR WHEEL HUB CPL. 85 SX 03	1
11	470.10.011.000	LAGERDISTANZROHR HINTEN 03	BEARING SPACER TUBE 85 SX 03	1
13	0760 324771	WELLENDICHTRING 32X47X7 BSL	SHAFT SEAL RING 32X47X7 BSL	2
14	0625 060058	RILLENKUGEL.6005 DDU2CG23S6NM	GR.BALL BEAR.6005 DDU2CG23S6NM	2
15	0472 047175	SICHERUNGSRING DIN0472-47X1,75	CIRCLIP DIN0472-47X1,75	1
16	546.10.016.000	BÜCHSE FÜR NABE	BUSHING FOR HUB	2
30	584.14.030.000	SK-BUNDMUTTER M10X1,25 SW=13	HH COLLAR NUT M10X1,25 WS=13	2
40	503.04.040.000	SCHRAUBE M10X1,25X40 SW=10	SPEC. SCREW M10X1,25X40 WS=10	2
51	470.10.051.044	KETTENRAD 44-Z 85 SX 03	REAR SPROCKET 44-T 85 SX 03	X
51	470.10.051.045	KETTENRAD 45-Z 85 SX 03	REAR SPROCKET 45-T 85 SX 03	X
51	470.10.051.046	KETTENRAD 46-Z 85 SX 03	REAR SPROCKET 46-T 85 SX 03	1
51	470.10.051.047	KETTENRAD 47-Z 85 SX 03	REAR SPROCKET 47-T 85 SX 03	X
51	470.10.051.048	KETTENRAD 48-Z 85 SX 03	REAR SPROCKET 48-T 85 SX 03	X
51	470.10.051.049	KETTENRAD 49-Z 85 SX 03	REAR SPROCKET 49-T 85 SX 03	X
51	470.10.051.050	KETTENRAD 50-Z 85 SX 03	REAR SPROCKET 50-T 85 SX 03	X
52	545.10.052.100	KETTENRADSCHR. M8X26 JSK SW=6	SPROCKET SCREW-AH M8X26 WS=6	4
53	543.10.086.200	STOVER-FLANSCHMUTTER M8 10.9	SELF LOCKING NUT M8 10.9	4
60	470.10.060.000	BREMSSCHEIBE HINTEN D=200MM 03	BRAKE DISC REAR D=200MM 03	1
62	590.09.062.013	SONDERSCHRAUBE M6X13 SW=8 10.9	SPECIAL SCREW M6X13 WS=8 10.9	4
65	470.10.165.124	KETTE 124 ROLLEN 85 SX	CHAIN 124 ROLLS 85 SX	1
66	470.10.166.000	KETTENSCHLOSS 85 SX	MASTER LINK 85 SX	1
70	470.10.070.000	FELGE HINTEN AL4 14X1,60-32 03	RIM REAR AL4 14X1,60-32 03	1
70	470.10.070.100	FELGE HINTEN AL4 15X1,60-32 03	RIM REAR AL4 15X1,60-32 03	X
70	470.10.070.200	FELGE HINTEN AL4 16X1,85-32 03	RIM REAR AL4 16X1,85-32 03	X
72	470.10.072.148	SPEICHE HI. 14" 4/3,5/4-148 03	SPOKE REAR 14" 4/3,5/4-148 03	32
72	470.10.072.162	SPEICHE HI. 15" 4/3,5/4-162 03	SPOKE REAR 15" 4/3,5/4-162 03	X
72	470.10.072.171	SPEICHE HI. 16" 4/3,5/4-171 03	SPOKE REAR 16" 4/3,5/4-171 03	X
73	503.09.072.000	SPEICHENNIPPEL M4,5X0,75 8X21	SPOKE NIPPLE M4,5X0,75 8X21	32
84	503.10.084.000	KETTENSPIANNER RECHTS 2000	CHAIN TENSIONER R/S 2000	1
85	470.10.085.044	STECKACHSE HI. KPL. 85 SX 2003	AXLE REAR CPL. 85 SX 2003	1
87	503.10.099.000	SK-MUTTER M20X1,5 '98	HEXAGON NUT M20X1,5 '98	1
89	550.03.135.000	BLINDSTOPFEN FÜR FELGE	PLUG FOR RIM	X
90	503.10.090.050	MUTTER FÜR REIFENHALTER '96	NUT FOR WHEEL HOLDER '96	1
91	510.09.100.100	REIFENHALTER VM1 (1,60")	RIM LOCK VM1 (1,60")	1

* = NEUTEIL / NEW PART X = NACH BEDARF / AS REQUIRED

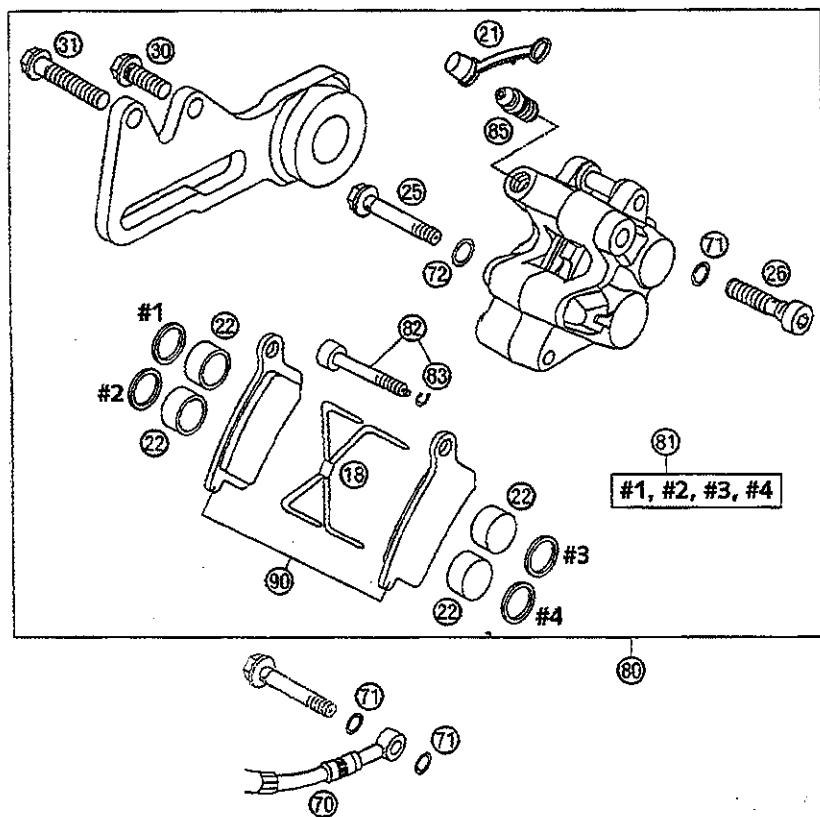
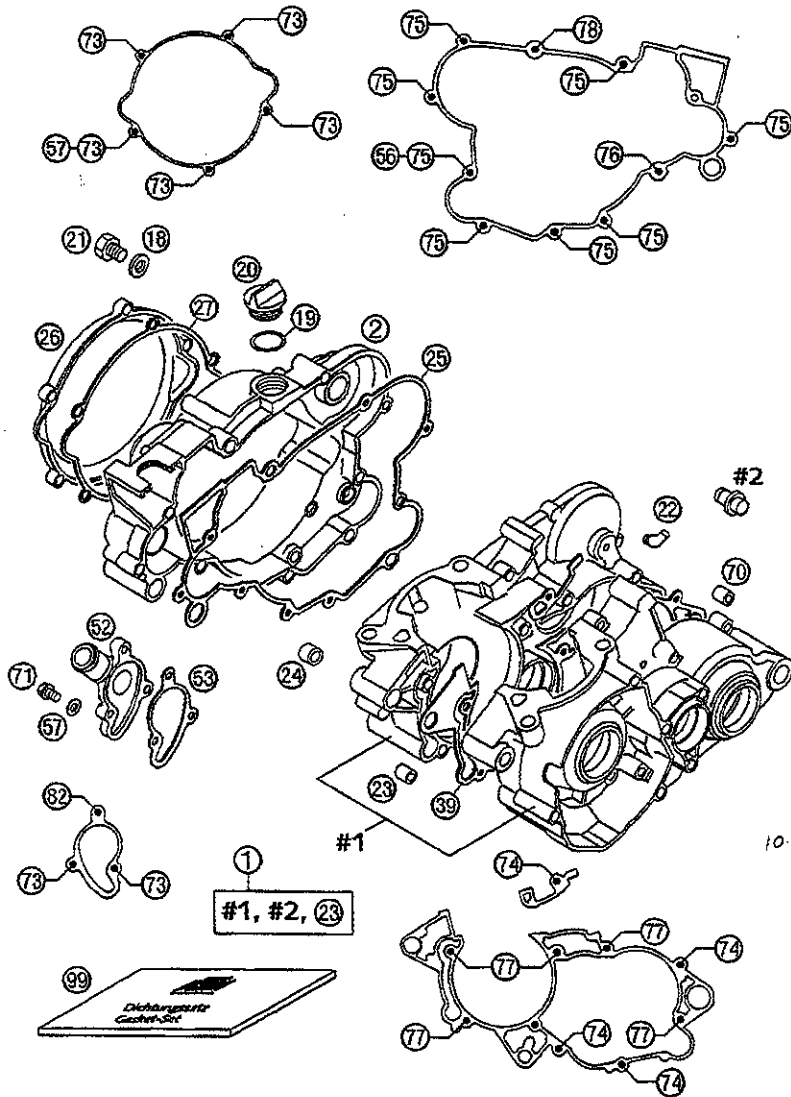
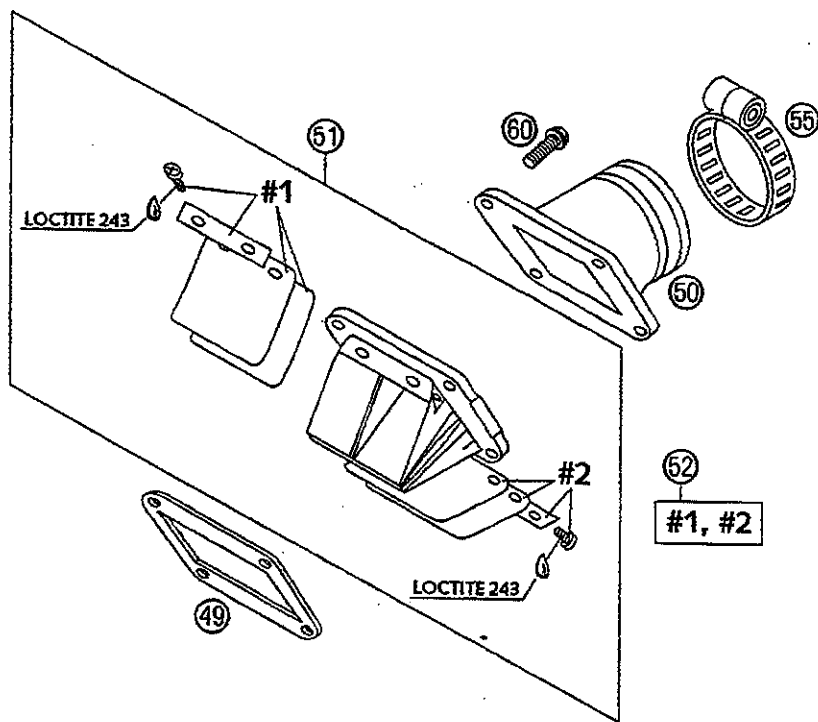


FIG	TEILNR/PARTNR	BEZEICHNUNG	DESCRIPTION	QTY
18*	✓ 461.13.018.000	HALTEFEDER 65 SX	RETAINING SPRING 65 SX	1
21	470.13.021.000	KAPPE FÜR ENTLÜFTUNGSSCHRAUBE	CAP FOR BLEEDER SCREW	1
22*	470.13.083.000	BREMSKOLBEN HINTEN 85SX 04	BRAKE PISTON REAR 85SX 04	4
25	470.13.225.000	HOHLSCHRAUBE HI. 85 SX 2003	HOLLOW SCREW REAR 85 SX 2003	1
26	470.13.325.000	HOHLSCHRAUBE HI. 85 SX 2003	HOLLOW SCREW REAR 85 SX 2003	1
30	0015 080203	SK.BUNDSCHRAUBE M 8X20 SW=10	HH COLLAR SCREW M 8X20 WS=10	1
31	0015 080403	SK.BUNDSCHRAUBE M 8X40 SW=10	HH COLLAR SCREW M 8X40 WS=10	1
70	470.13.070.000	BREMSSCHLAUCH HINTEN 85 SX 03	BRAKE HOSE REAR 85 SX 03	1
71	0770 080019	O-RING 8,00X1,00 EPDM	O-RING 8,00X1,00 EPDM	3
72	0770 100019	O-RING 10X1 EPDM	O-RING 10X1 EPDM	2
80	470.13.080.000	BREMSZANGE HINTEN KPL.85 SX 03	BRAKE CALIPER RE. CPL.85 SX 03	1
81	470.13.081.000	REP. SATZ DICHRING HINTEN 03	REPAIR KIT SEAL RING REAR 03	1
82	461.13.125.000	ISK.SCHRAUBE + S-RING 2002	AH SCREW + CIRCLIP 2002	1
83	0799 040009	SICH.SCHEIBE DIN6799-RA 4,0	TAB WASHER DIN6799-RA 4,0	1
85	470.13.085.000	ENTLÜFTUNGSSCHRAUBE M8X1	BLEEDER SCREW M8X1	1
90	470.13.090.000	GARN. BREMSKLÖTZE HINTEN 2003	BRAKE PAD SET REAR 2003	1

FIG	TEILNR/PARTNR	BEZEICHNUNG	DESCRIPTION	QTY
1	470.30.000.044	MOTORGEHÄUSE KPL. 85 SX 2003	ENGINE CASE CPL. 85 SX 2003	1
2	470.30.001.000	KUPPLUNGSDECKEL KPL. 85 SX 03	CLUTCH COVER CPL. 85 SX 03	1
18	0603 101420	DICHTRING 10,2X14X2 MM CU 01	COPPER GASKET 10,2X14X2 MM 01	1
19	0770 160030	O-RING 16,00X3,00 NBR 70	O-RING 16,00X3,00 NBR 70	1
20	580.30.020.000	ÖLEINFÜLLSCHRAUBE M 24X3	PLUG M 24X3	1
21	460.30.021.100	ÖLABLASSSCHRAUBE M10 SW=13	OIL DRAIN PLUG M10 WS=13	1
22	451.30.022.000	WINKELSTÜCK 50CCM LC 2001	ANGLE PIECE 50CCM LC 2001	1
23	470.30.023.100	PASSHÜLSE 13X13	DOWEL 13X13	1
24	451.30.023.000	PASSHÜLSE 7X9X10	DOWEL 7X9X10	1
25	470.30.025.000	KUPPLUNGSDECKELDICHTUNG INNEN	INNER CLUTCH COVER GASKET	1
26	470.30.101.000	KUPPLUNGS-AUSSENDECKEL 85 SX 03	OUTER CLUTCH OVER 85 SX 03	1
27	470.30.027.000	KUPPLUNGSDECKELDICHTUNG AUSSEN	GASKET FOR OUTER CLUTCH COVER	1
39	470.30.039.000	MOTORGEHÄUSEDICHTUNG 85 SX 03	GASKET F. ENGINE CASE 85 SX 03	1
52	470.35.052.000	WASSERPUMPENDECKEL 85 SX 2003	WATER PUMP COVER 85 SX 2003	1
53	470.35.053.000	WASSERPUMPENDECKELDICHTUNG 03	GASKET FOR WATER PUMP COVER 03	1
56	470.03.071.000	FEDERLASCHE	SPRINGHOLDER	1
57	0603 061001	CU-DICHTRING DIN7603-6X10X1	CU-SEAL RING DIN7603-6X10X1	2
70	470.30.023.000	PASSHÜLSE 14,5X19	DOWEL 14,5X19	1
71	0015 060103	SK.BUNDSCHRAUBE M 6X10 SW=8	HH COLLAR SCREW M 6X10 WS=8	1
73	0015 060203	SK.BUNDSCHRAUBE M 6X20 SW=8	HH COLLAR SCREW M 6X20 WS=8	7
74	0015 060253	SK.BUNDSCHRAUBE M 6X25 SW=8	HH COLLAR SCREW M 6X25 WS=8	4
75	0015 060303	SK.BUNDSCHRAUBE M 6X30 SW=8	HH COLLAR SCREW M 6X30 WS=8	8
76	0015 060353	SK.BUNDSCHRAUBE M 6X35 SW=8	HH COLLAR SCREW M 6X35 WS=8	1
77	0015 060403	SK.BUNDSCHRAUBE M 6X40 SW=8	HH COLLAR SCREW M 6X40 WS=8	5
78	0015 060453	SK.BUNDSCHRAUBE M 6X45 SW=8	HH COLLAR SCREW M 6X45 WS=8	1
82	0015 060653	SK.BUNDSCHRAUBE M 6X65 SW=8	HH COLLAR SCREW M 6X65 WS=8	1
99	470.30.099.100	DICHTUNGSSATZ KPL. 85/105SX 04	GASKET SET CPL. 85/105SX 04	1

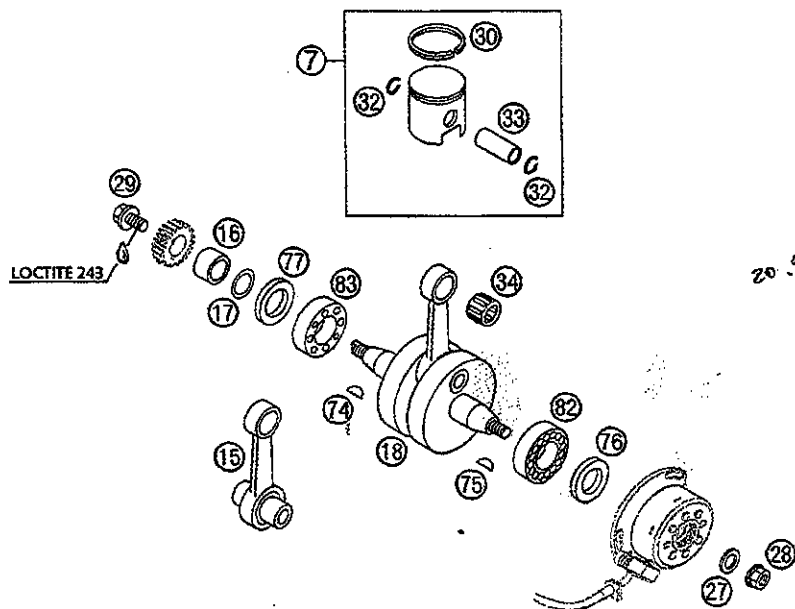


~FIG	TEILNR/PARTNR	BEZEICHNUNG	DESCRIPTION	QTY
49	470.30.049.000	ANSAUGFLANSCHDICHTUNG 85 SX 03	GASKET FOR INTAKE FLANGE 85 SX	1
50	470.30.050.000	ANSAUGFLANSCH 85 SX 2003	INTAKE FLANGE 85 SX 2003	1
51	470.30.051.044	MEMBRANGEHÄUSE KPL. 85 SX 2003	REED VALVE ASSY CPL. 85 SX 2003	1
52	470.30.052.004	MEMBRANBLÄTTER KPL. 85 SX 2003	REED VALVE CPL. 85 SX 2003	2
55	512.30.061.000	SCHELLE 40/12 GEMI	CLAMP 40/12 GEMI	1
60	0015 060203	SK.BUNDSCHRAUBE M 6X20 SW=8	HH COLLAR SCREW M 6X20 WS=8	4



MOTOTECH
MOTORCYCLE TECHNOLOGY

FIG	TEILNR/PARTNR	BEZEICHNUNG	DESCRIPTION	QTY
7	470.30.007.000/ I	KOLBEN KPL. 47MM GR.1 2003	PISTON CPL. 47MM SIZE 1 2003	1
7	470.30.007.000/ II	KOLBEN KPL. 47MM GR.2 2003	PISTON CPL. 47MM SIZE 2 2003	1
15	470.30.015.000	PLEUELREPSATZ 85 SX 2003	CON. ROD. REP. KIT 85 SX 2003	1
16	470.30.016.000	DISTANZHÜLSE 85 SX 2003	SPACER SLEEVE 85 SX 2003	1
17	0770 020180	O-RING 18,77X1,78 NBR 70	O-RING 18,77X1,78 NBR 70	1
18	470.30.018.000	KURBELWELLE KPL. 85 SX 2003	CRANKSHAFT CPL. 85 SX 2003	1
27	502.30.029.012	SPERRKANTRING VSK 12	LOCKING RING VSK 12	1
28	490.30.021.000	BUNDMUTTER M12X1 RECHTS	COLLAR NUT M12X1 R/S	1
29	470.32.019.000	SK-SCHRAUBE M.BUND M10X1,25X20	HH SCREW W. COLLAR M10X1,25X20	1
30	470.30.030.000	KOLBENRING 85 SX 2003	PISTON RING 85 SX 2003	1
32	470.30.074.000	DRAHTSPRENGRING 85 SX 2003	WIRE LOCK RING 85 SX 2003	2
33	470.30.033.000	KOLBENBOLZEN 85 SX 2003	PISTON PIN 85 SX 2003	1
34	470.30.034.000	NADELLAGER KBK 14X18X17 2003	NEEDLE BEARING KBK 14X18X17 03	1
74	0888 040050	SCHEIBENFEDER DIN6888-4X5X13	WOODRUFF KEY DIN6888 4X5X13	1
75	0888 030050	SCHEIBENFEDER DIN6888-3X5X13	WOODRUFF KEY DIN6888-3X5X13	1
76*	470.30.076.100	WELLENDICHTRING 20X35X6 BTSL	SEAL SHAFT RING 20X35X6 BTSL	1
77	0760 304260	WELLENDICHTRING 30X42X6	SHAFT SEAL RING 30X42X6	1
82	470.30.082.000	ZYL.ROLLENLAGER NJ 205ET2XCS42	CYL.ROLLER BEAR. NJ205ET2XCS42	1
83	470.30.083.000	RILLENKUGELLAGER 22X52X15	BALL BEARING 22X52X15	1



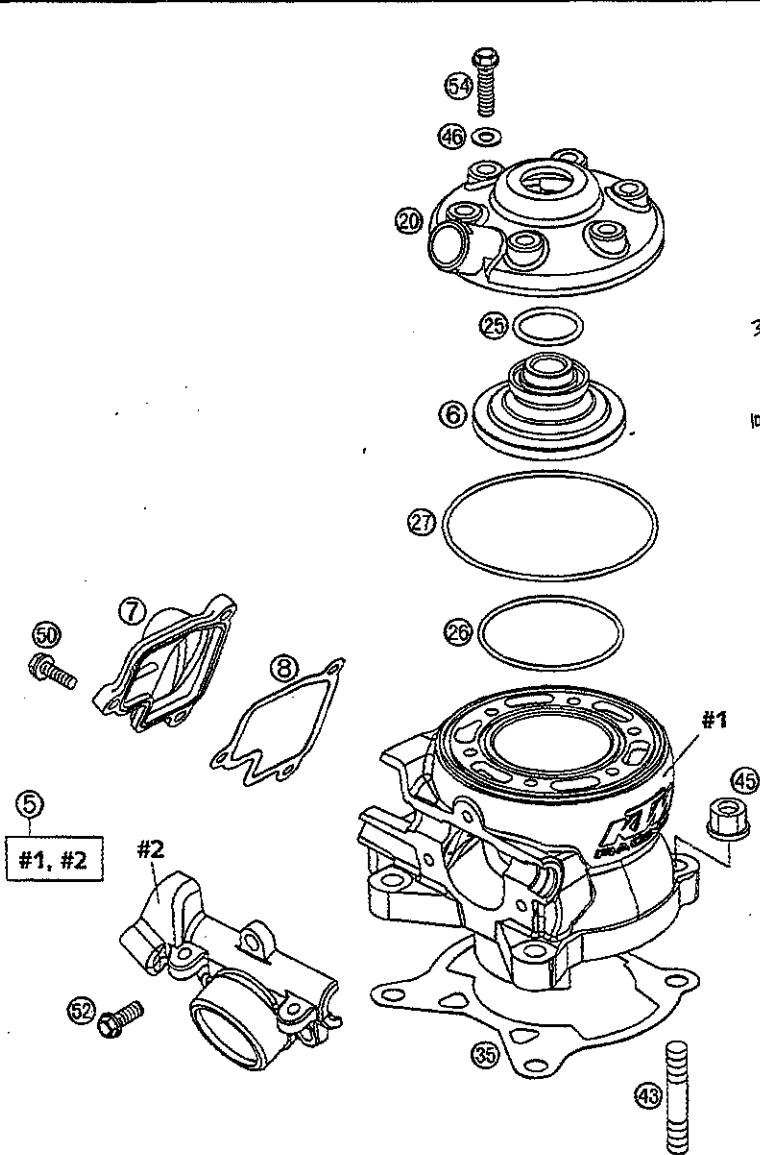


FIG	TEILNR/PARTNR	BEZEICHNUNG	DESCRIPTION	QTY
5	470.30.005.044	ZYLINDER M. FLANSCH 85 SX 2003	CYLINDER W. FLANGE 85 SX 2003	1
6	470.30.106.000	ZYLINDERKOPFEINSATZ 85 SX 2003	CYLINDER HEAD INSERT 85 SX 03	1
7	470.37.007.000	STEUERDECKEL 85 SX 2003	CONTROL COVER 85 SX 2003	1
8	470.37.008.000	DICHTUNG F. STEUERDECKEL 2003	GASKET FOR CONTROL COVER 2003	1
20	470.30.006.000	ZYLINDERKOPF 85 SX 2003	CYLINDER HEAD 85 SX 2003	1
25	0770 220025	O-RING 22,00X2,5 VITON 75SH	O-RING 22,00X2,5 VITON 75SH	1
26	0770 540020	O-RING 54X2 VITON	O-RING 54X2 VITON	1
27	0770 820020	O-RING 82X2 SILIKON	O-RING 82X2 SILICONE	1
30 80 / 35 * N	470.30.035.020	ZYLINDERFUSSDICHTUNG 0,20MM	CYLINDER BASE GASKET 0,20MM	X
30 50 / 35 * N	470.30.035.030	ZYLINDERFUSSDICHTUNG 0,30MM	CYLINDER BASE GASKET 0,30MM	X
35	470.30.035.000	ZYLINDERFUSSDICHTUNG 0,50MM	CYLINDER BASE GASKET 0,50MM	X
10 -20 / 43 * N	0835 080240	STIFTSCHRAUBE DIN0835-M 8X24	STUD DIN 0835-M 8X24	4
45	460.30.045.000	BUNDMÜTTER M8 SW=10	COLLAR NUT M8 WS=10	4
46	0603 061001	CU-DICHTRING DIN7603-6X10X1	CU-SEAL RING DIN7603-6X10X1	6
50	0015 050123	SK.BUNDSCHRAUBE M 5X12 SW=8	HH COLLAR SCREW M 5X12 WS=8	3
52	0015 060163	SK.BUNDSCHRAUBE M 6X16 SW=8	HH COLLAR SCREW M 6X16 WS=8	3
54	0015 060253	SK.BUNDSCHRAUBE M 6X25 SW=8	HH COLLAR SCREW M 6X25 WS=8	6

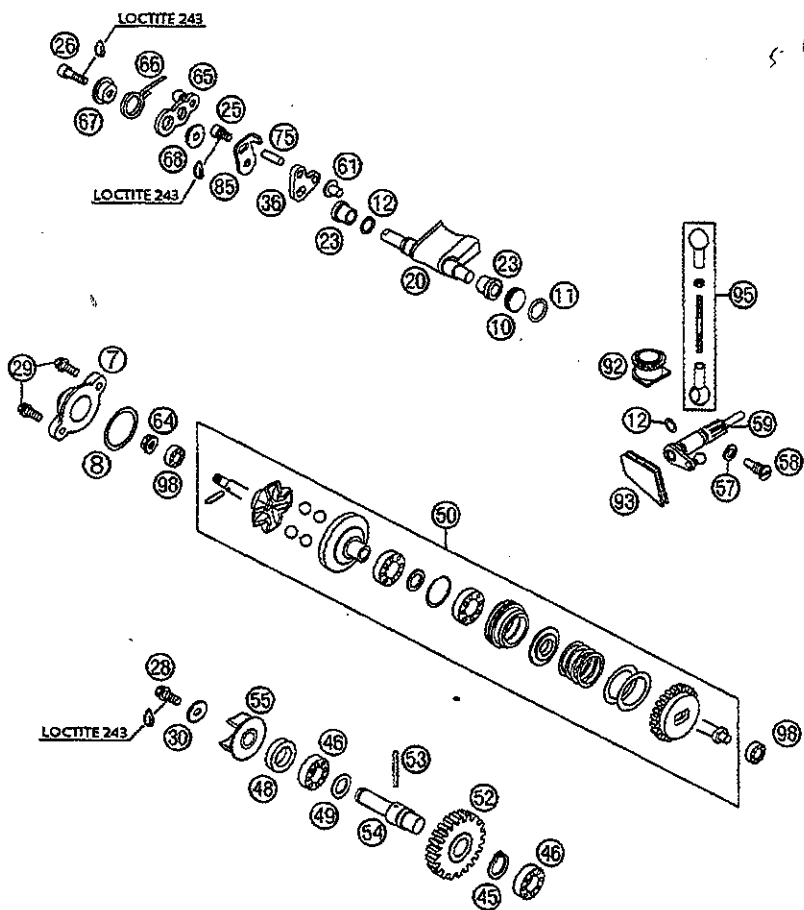
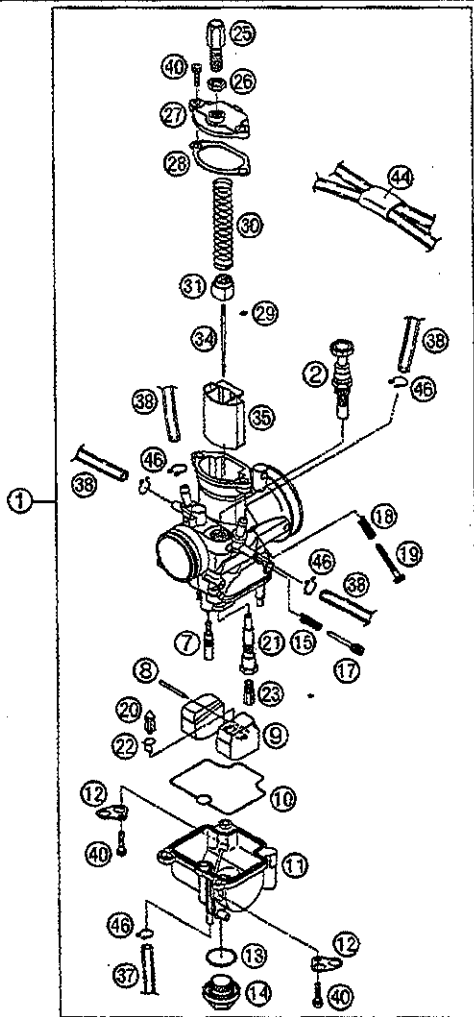


FIG	TEILNR/PARTNR	BEZEICHNUNG	DESCRIPTION	QTY
7	546.37.070.200	VERSCHLUSSDECKEL 2003	CLOSING COVER 2003	1
8	0770 020200	O-RING 21,95X1,78 NBR	O-RING 21,95X1,78 NBR	1
10	470.37.010.000	VERSCHLUSSDECKEL 85 SX 2003	CLOSING COVER 85 SX 2003	1
11	0770 120020	O-RING 12,00X2,00 NBR 70	O-RING 12,00X2,00 NBR 70	1
12*	0770 008015	O-RING 8,00X1,5	O-RING 8,00X1,5	2
20	470.37.020.000	STEUERKLAPPE 85 SX 03	CONTROL FLAP 85 SX 03	1
23	470.37.023.000	LAGERHÜLSE 85 SX 2003	BEARING SLEEVE 85 SX 2003	2
25	0912 050083	ISK.SCHRAUBE DIN 912 M 5X8	AH SCREW DIN0912-M 5X 8	1
26	0912 050163	ISK.SCHRAUBE DIN 912 M5X16	AH SCREW DIN0912-M 5X16	1
28	0015 050123	SK.BUNDSCHRAUBE M 5X12 SW=8	HH COLLAR SCREW M 5X12 WS=8	1
29	0015 050203	SK.BUNDSCHRAUBE M 5X20 SW=8	HH COLLAR SCREW M 5X20 WS=8	2
30	0349 000050	SCHIEBE DIN7349-5X15X2	WASHER DIN7349-5X15X2	1
36	470.37.036.000	MITNEHMERBLECH 85 SX 2003	DRIVER SHEET 85 SX 2003	1
45	0471 100010	SICHERUNGSRING DIN0471-10X1	CIRCLIP DIN0471-10X1	1
46	0625 006087	RILLENKUGELLAGER 608 2RS C3	GROOVED BALL BEAR. 608 2RS C3	2
48	0760 082472	WELLENDICHTRING 8X24X7 A DUO	SHAFT SEAL RING 8X24X7 A DUO	1
49	543.34.015.000	SCHIEBE 10X14X0,5 STAHL	WASHER 10X14X0,5 STEEL	1
50	470.37.050.044	FLIEHKRAFTVERSTELLER KPL. 03	CENTRIFUGAL TIMER CPL. 03	1
52	470.35.054.026	WASSERPUMPENANTRIEBSRAD 2003	WATER PUMP GEAR 2003	1
53	470.35.058.000	ZYLINDERSTIFT 2X22	PIN 2X22	1
54	470.35.054.000	WASSERPUMPENWELLE 85 SX 2003	WATER PUMP SHAFT 85 SX 2003	1
55	470.35.055.000	WASSERPUMPENRAD 85 SX 2003	WATER PUMP WHEEL 85 SX 2003	1
57	0603 040801	CU-DICHTRING DIN7603- A4X8X1	COPPER GASKET DIN7603- A4X8X1	1
58	470.37.058.000	ARRETIERSCHRAUBE VERSTELLW. 03	LOCK SCREW CONTROL SHAFT 03	1
59	470.37.057.000	VERSTELLWELLE 85 SX 03	CONTROL SHAFT 85 SX 03	1
61	470.35.061.000	VERSCHLUSSSCHRAUBE M6X8	SCREW M6X8	1
64	565.09.064.100	STOVER-FLANSCHMUTTER M6 10.9	SELF LOCKING NUT M6 10.9	1
65	470.37.065.000	EINSTELLHEBEL 85 SX 2003	CONTROL LEVER 85 SX 2003	1
66	546.37.066.000	ÜBERLASTFEDER	OVERLOAD SPRING	1
67	470.37.067.000	FEDERHÜLSE 85 SX 2003	SPRING SLEEVE 85 SX 2003	1
68	470.37.068.000	LAGERHÜLSE 85 SX 2003	BEARING SLEEVE 85 SX 2003	1
75	0007 050180	ZYLINDERSTIFT DIN 7-5X18(MM)	CYLINDER PIN DIN 7-5X18(M6)	1
85	470.37.085.000	ANSCHLAGBLECH 85 SX 2003	STOP SHEET 85 SX 2003	1
92	470.37.092.000	DICHTELEMENT OBEN 85 SX	GASKET RUBBER TOP 85 SX	1
93	470.37.093.000	DICHTELEMENT UNTEN 85 SX	GASKET RUBBER BOTTOM 85 SX	1
95	470.37.095.044	GESTÄNGE KPL. 85 SX 03	CONNECT. ROD CPL. 85 SX 03	1
98	546.37.098.100	RILLENKUGELLAGER 626LLBC3/5K	BALL BEARING 626LLBC3/5K	2

ACHTUNG !!
 Vor dem Einbau des Vergasers, Bedüsung kontrollieren.
CAUTION !!
 Before mounting the carburetor, check the jetting.



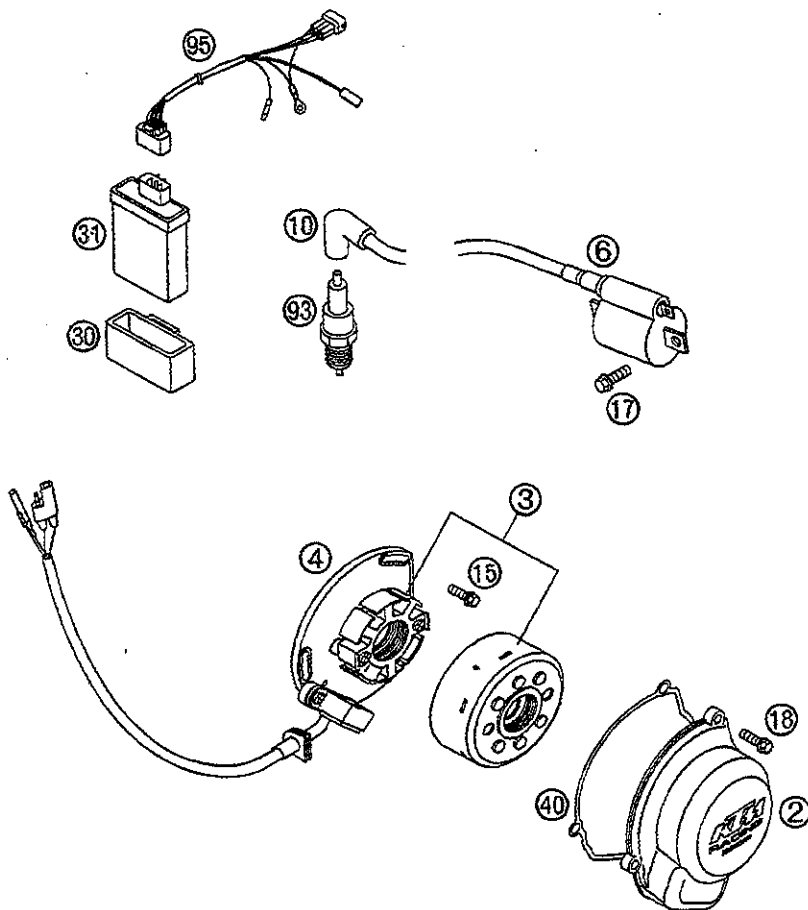
03-470.31.0

FIG	TEILNR/PARTNR	BEZEICHNUNG	DESCRIPTION	QTY
1	470.31.001.000	VERGASER KEIHIN PWK 28 2003	CARBURETOR KEIHIN PWK 28 2003	1
2	546.31.245.000	STARTKOLBEN KPL.	STARTER PISTON CPL.	1
7	545.31.607.045	LEERLAUFDÜSE GR.45 KEIHIN	IDLE JET 45 KEIHIN	1
8	573.31.008.000	STIFT SCHWIMMER	ARM PIN FLOAT	1
9	470.31.009.000	SCHWIMMER KPL. PWK28 03	FLOAT CPL. PWK28 03	1
10	470.31.010.000	SCHWIMMERGEHÄUSEDICHTUNG	FLOAT CHAMBER GASKET	1
11	470.31.011.000	SCHWIMMERGEHÄUSE PWK28 03	FLOAT CHAMBER PWK28 03	1
12	545.31.612.100	HALBLECH F. ENTLÜFTUNGSSCHL.	RETAINING PLATE FOR BLEEDER	2
13	0770 180230	O-RING 18,00X2,30 NBR 70	O-RING 18,00X2,30 NBR 70	1
14	573.31.014.000	VERSCHLUSSSCHRAUBE	HOLDING BOLT	1
15	545.31.615.000	FEDER FÜR STELSCHRAUBE	SPRING FOR ADJUSTMENT SCREW	1
17	545.31.617.000	STELLSCHRAUBE	ADJUSTMENT SCREW	1
18	546.31.118.000	FEDER	SPRING	1
19	546.31.219.100	STELLSCHRAUBE M 5	ADJUSTMENT SCREW M 5	1
20	470.31.020.000	SCHWIMMERNADEL KPL.	FLOAT NEEDLE CPL.	1
21	470.31.021.000	NAELEDÜSE	NEEDLE JET	1
22	470.31.022.000	KLAMMER SCHWIMMERNADEL	CLIP FOR FLOAT VALVE	1
23	545.31.623.115	HAUPTDÜSE GR.115 KEIHIN	MAIN JET 115 KEIHIN	X
23	545.31.623.118	HAUPTDÜSE GR.118 KEIHIN	MAIN JET 118 KEIHIN	1
23	545.31.623.120	HAUPTDÜSE GR.120 KEIHIN	MAIN JET 120 KEIHIN	X
23	545.31.623.122	HAUPTDÜSE GR.122 KEIHIN	MAIN JET 122 KEIHIN	X
25	545.31.625.000	STELLSCHRAUBE M 6X0,75	ADJUSTMENT SCREW M 6X0,75	1
26	520.31.126.000	SK.MUTTER M 6X0,75 DIN0439	HEXAGON NUT M 6X0,75 DIN0439	1
27	470.31.027.000	VERGASERDECKEL PWK28 03	CARBURETOR COVER PWK28 03	1
28	470.31.028.000	VERGASERDECKELDICHTUNG PWK28	CARBURETOR COVER GASKET PWK28	1
29	545.31.629.000	KLEMMFEDER	CLIP FOR JET NEEDLE	1
30	470.31.030.000	GASSCHIEBERFEDER	THROTTLE VALVE SPRING	1
31	470.31.031.000	FEDERTASSE	SPRING CAP	1
34	470.31.034.000	DÜSENNADEL N5HG KEIHIN	JET NEEDLE N5HG KEIHIN	1
34	470.31.034.100	DÜSENNADEL N5HF KEIHIN	JET NEEDLE N5HF KEIHIN	X
34	470.31.034.200	DÜSENNADEL N5HH KEIHIN	JET NEEDLE N5HH KEIHIN	X
35	470.31.035.000	GASSCHIEBER 3,5	THROTTLE VALVE 3,5	1
37	520.31.137.001	PVC-SCHLAUCH 3X5MM	PVC-HOSE 3X5MM	0,33
38	310.07.007.101	PVC-SCHLAUCH 4X6MM	PVC-HOSE 4X6MM	2,2
40	0016 040163	SK.BUNDSCHRAUBE M 4X16 SW=6	HH COLLAR SCREW M 4X16 WS=6	4
44	470.31.084.000	PLASTIK-KLAMMER	PLASTIC-CLIP	1
46	545.31.696.000	KLAMMER 6 MM	CLAMP 6 MM	5

* = NEUTEIL / NEW PART

X = NACH BEDARF / AS REQUIRED

FIG	TEILNR/PARTNR	BEZEICHNUNG	DESCRIPTION	QTY
2	470.30.002.000	ZÜNDUNGSDECKEL 85 SX 2003	IGNITION COVER 85 SX 2003	1
3	461.39.002.100	ZÜNDANLAGE KPL. 65 SX 2003	IGNITION CPL. 65 SX 2003	1
4	461.39.004.000	STATOR 65/85 SX 2003	STATOR 65/85 SX 2003	1
6	461.39.006.100	ZÜNDSPULE KPL. 65 SX 2003	IGNITION COIL CPL. 65 SX 2003	1
10*	470.39.090.000	KERZENSTECKER NGK VERSTÄRKT 04	SPARK PLUG CAP NGK REINFORC.04	1
15	0015 050163	SK.BUNDSCHRAUBE M 5X16 SW=8	HH COLLAR SCREW M 5X16 WS=8	3
17	0015 060163	SK.BUNDSCHRAUBE M 6X16 SW=8	HH COLLAR SCREW M 6X16 WS=8	2
18	0015 060203	SK.BUNDSCHRAUBE M 6X20 SW=8	HH COLLAR SCREW M 6X20 WS=8	3
30	461.39.030.000	HALTEGUMMI DIGI.BOX 65SX 2003	RUBBER BR. DIGI.BOX 65SX 2003	1
31	470.39.031.000	ELEKTRONIKBOX 85 SX 2003	CDI UNIT 85 SX 2003	1
40	470.30.040.000	ZÜNDUNGSDECKELDICHUNG 85SX 03	IGNITION COVER GASKET 85 SX 03	1
93	470.39.093.000	ZÜNDKERZE NGK BR10 ECMVX	SPARK PLUG NGK BR10 ECMVX	1
95	461.39.095.000	KABELSTRANG 65 SX 2003	WIRING HARNESS 65 SX 2003	1



MOTOTECH
MOTORCYCLE TECHNOLOGY

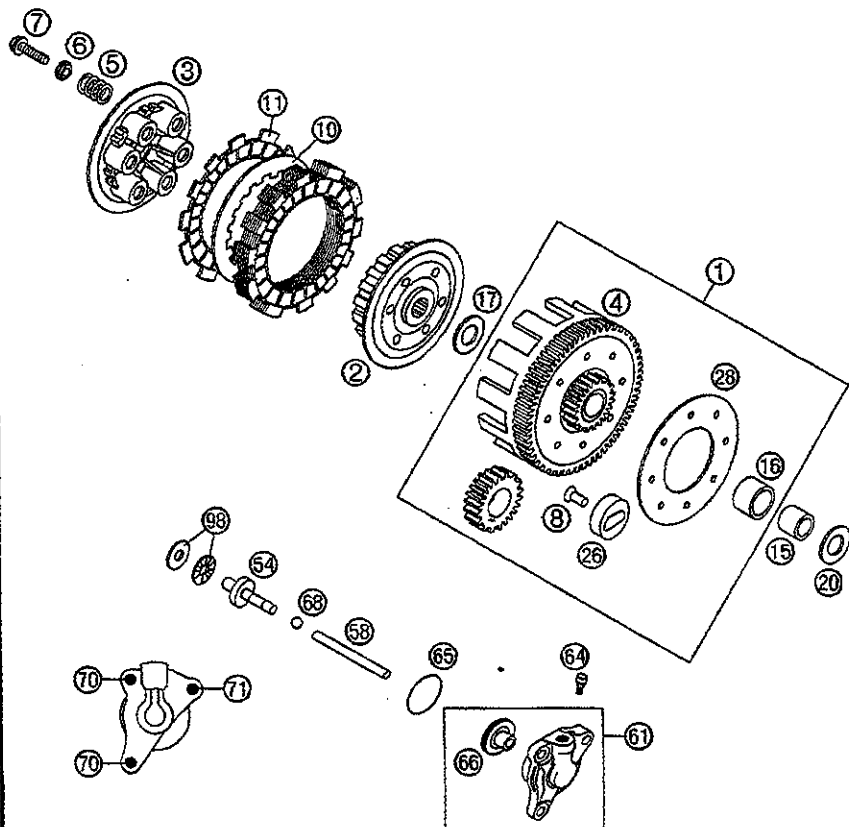


FIG	TEILNR/PARTNR	BEZEICHNUNG	DESCRIPTION	QTY
1	470.32.001.044	KUPPLUNGSKORB KPL. 85 SX 03	OUTER CLUTCH HUB CPL. 85 SX 03	1
2	470.32.002.000	MITNEHMER 85 SX 2003	INNER CLUTCH HUB 85 SX 2003	1
3	470.32.003.000	DRUCKKAPPE 85 SX 2003	PRESSURE CAP 85 SX 2003	1
4	470.32.001.000	KUPPLUNGSKORB LOSE 85 SX 03	OUT. CLUTCH HUB LOOSE 85 SX 03	1
5	470.32.005.000	KUPPLUNGSFEDER 85 SX 2003	CLUTCH SPRING 85 SX 2003	5
6	470.32.006.000	FEDERTELLER 5,1X10,2X15X2,5	SPRING RETAIN. 5,1X10,2X15X2,5	5
7	0015 050203	SK.BUNDSCHRAUBE M 5X20 SW=8	HH COLLAR SCREW M 5X20 WS=8	5
8	470.32.008.000	NIETE DIN0661 5X14	RIVET DIN0661 5X14	8
10	470.32.010.000	ZWISCHENLAMELLE STAHL 85 SX 03	STEEL DISC 85 SX 03	6
11	470.32.011.000	BELAGLAMELLE 85 SX 2003	LINING DISC 85 SX 2003	7
15	470.32.015.000	BÜCHSE 20X25X20,5	BUSHING 20X25X20,5	1
16	470.32.016.000	INNENRING 25X28X20	INNER RING 25X28X20	1
17	470.32.017.000	STÜTZSCHEIBE 18,5X35X1,5 03	SUPPORT WASHER 18,5X35X1,5 03	1
20	470.32.020.000	ANLAUFSCHLEIFE 20X32X2	STOP DISC 20X32X2	1
26	470.32.026.000	DÄMPFERELEMENT 85 SX 2003	DAMPING ELEMENT 85 SX 2003	8
28	470.32.028.000	HALTEBLECH 85 SX 2003	RETAINING PLATE 85 SX 2003	1
54	470.32.054.000	DRUCKPILZ 85 SX 2003	PRESSURE PLATE 85 SX 2003	1
58	470.32.058.000	DRUCKSTANGE 85 SX 2003	PUSH ROD 85 SX 2003	1
61	590.32.061.044	NEHMERZYLINDER KPL. 2003	OUTPUT CYLINDER CPL. 2003	1
64	547.32.064.000	ENTLÜFTUNGSSCHR. MIT KAPPE	BLEEDER SCREW WITH CAP	1
65	0770 300015	O-RING 30,00X1,50 NBR 70	O-RING 30,00X1,50 NBR 70	1
66	590.32.066.000	KOLBEN MIT O-RING UND KUGEL 03	PISTON WITH O-RING AND BALL 03	1
68	470.32.068.000	KUGEL D=6MM 85 SX 2003	BALL D=6MM 85 SX 2003	1
70	0015 060163	SK.BUNDSCHRAUBE M 6X16 SW=8	HH COLLAR SCREW M 6X16 WS=8	2
71	0015 060203	SK.BUNDSCHRAUBE M 6X20 SW=8	HH COLLAR SCREW M 6X20 WS=8	1
98	470.32.098.000	AXIALLAGER 85 SX 2003	AXIAL NEEDLE BEARING 85 SX 03	1

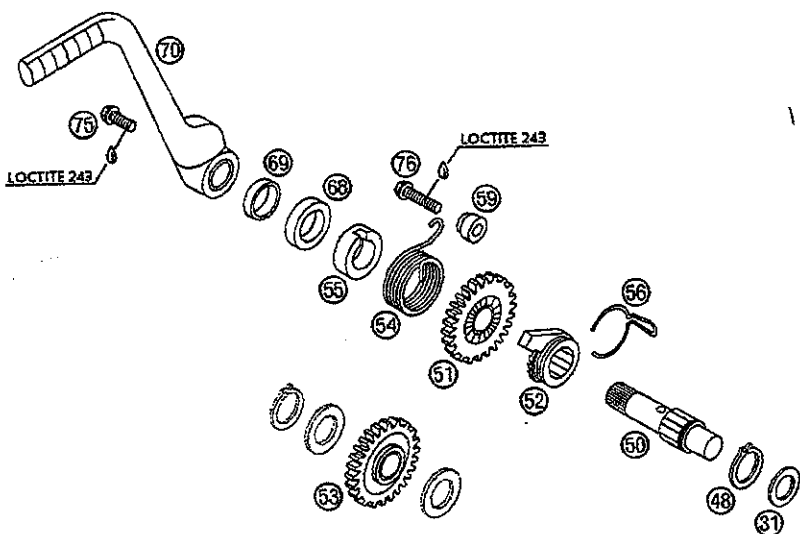
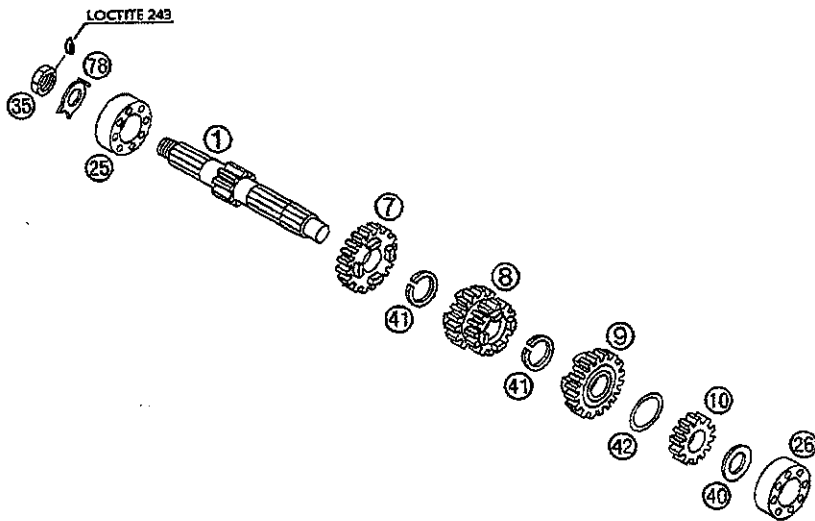


FIG	TEILNR/PARTNR	BEZEICHNUNG	DESCRIPTION	QTY
31	470.33.040.000	ANLAUFSCHEIBE 15X25X1	STOP DISC 15X25X1	1
48	0471 190120	SICHERUNGSRING DIN0471-19X1,2	CIRCLIP DIN0471-19X1,2	1
50	470.33.050.000	KICKSTARTERWELLE 85 SX 2003	KICKSTART SHAFT 85 SX 2003	1
51	470.33.051.000	STARTERRAD 85 SX 2003	KICKSTART GEAR 85 SX 2003	1
52	470.33.052.000	SPERRAD 85 SX 2003	RATCHET GEAR 85 SX 2003	1
53	470.33.053.000	STARTERZWISCHENRAD 2003	KICKST. INTERMEDIATE GEAR 2003	1
54	470.33.054.000	KICKSTARTERFEDER 85 SX 2003	KICKSTART SPRING 85 SX 2003	1
55	460.33.055.000	MITNEHMERNABE	DRIVING HUB	1
56	470.33.056.000	SPERRADFEDER 85 SX 2003	RATCHET GEAR SPRING 85 SX 2003	1
59	470.33.059.000	FEDERBÜCHSE 85 SX 2003	SPRING SPACER 85 SX 2003	1
68	0760 142460	WELLENDICHTRING 14X24X6 B	SHAFT SEAL RING 14X24X6 B	1
1-2 69*	470.33.044.000	DISTANZ FÜR KICKSTARTER	SPACER BUSH FOR KICKSTARTER	1
70	470.33.070.000	KICKSTARTER KPL. 85 SX 2003	KICKSTARTER CPL. 85 SX 2003	1
75	0015 060163	SK.BUNDSCHRAUBE M 6X16 SW=8	HH COLLAR SCREW M 6X16 WS=8	1
76	0015 050253	SK.BUNDSCHRAUBE M 5X25 SW=8	HH COLLAR SCREW M 5X25 WS=8	1

FIG	TEILNR/PARTNR	BEZEICHNUNG	DESCRIPTION	QTY
1	470.33.001.000	ANTRIEBSWELLE 11-Z 85 SX 2003	MAIN SHAFT 11-T 85 SX 2003	1
7	470.33.007.000	LOSRAD 5.G. 21-Z 03	IDLER GEAR 5TH G. 21-T 03	1
8	470.33.008.000	SCHIEBERAD 3./4.G. 16/19-Z 03	SLID. GEAR 3RD/4TH G. 16/19-T	1
9	470.33.009.000	LOSRAD 6.G. 20-Z 03	IDLER GEAR 6TH G. 20-T 03	1
10	470.33.010.000	FESTRAD 2.G. 14-Z 03	SOLID GEAR 2ND G. 14-T 03	1
25	460.33.028.000	RILLENKUGELLAGER 20X42X12	GROOVED BALL BEARING 20X42X12	1
26	470.33.026.000	RILLENKUGELLAGER 16X35X8	BALL BEARING 16X35X8	1
35	460.30.029.000	SK.MUTTER 14X1,25X7 SW=22	HH NUT 14X1,25X7 WS=22	1
40	470.33.041.000	ANLAUFSCHIEBE 16X26X1	STOP DISC 16X26X1	1
41	470.33.096.000	AXIALSICHERUNG 19 SW	AXIAL CIRCLIP 19 SW	2
42	470.33.042.000	ANLAUFSCHIEBE 20,3X26X0,4	STOP DISC 20,3X26X0,4	1
78	460.30.078.000	SICHERUNGSBLECH D=14MM	LOCKING PLATE D=14MM	1



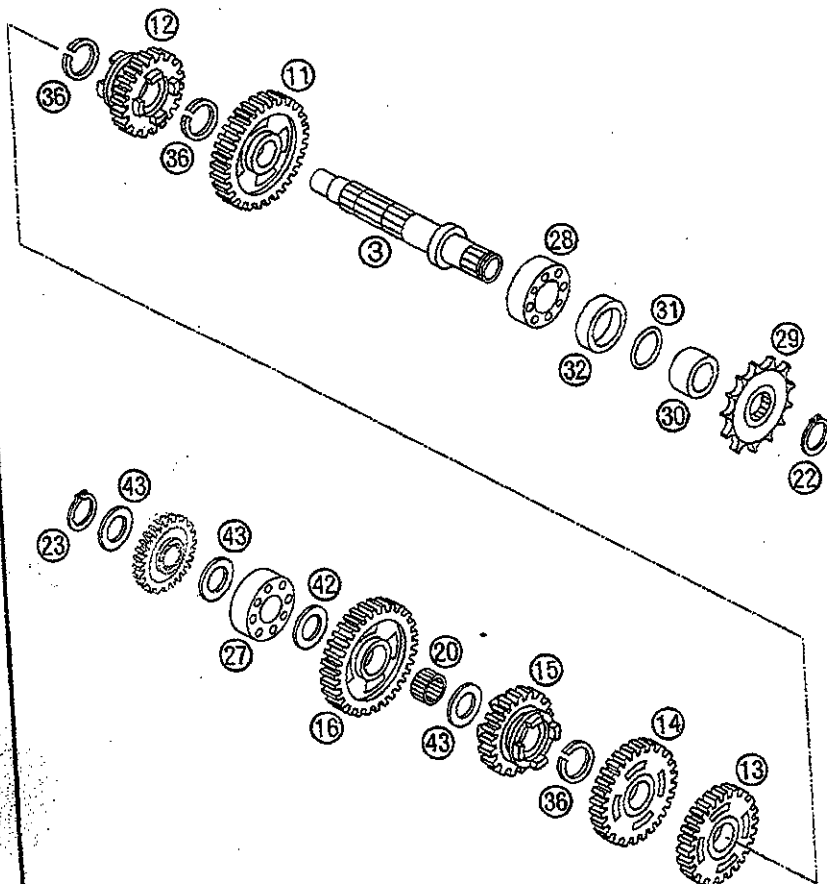


FIG	TEILNR/PARTNR	BEZEICHNUNG	DESCRIPTION	QTY
3	470.33.003.000	ABTRIEBSWELLE 85 SX	COUNTERSHAFT 85 SX	1
11	470.33.011.000	LOSRAD 2.G. 28-Z	IDLER GEAR 2ND G. 28-T	1
12	470.33.012.000	SCHIEBERAD 6.G. 21-Z	SLIDING GEAR 6TH G. 21-T	1
13	470.33.013.000	LOSRAD 3.G. 26-Z	IDLER GEAR 3ND G. 26-T	1
14	470.33.014.000	LOSRAD 4.G. 26-Z	IDLER GEAR 4TH G. 26-T	1
15	470.33.015.000	SCHIEBERAD 5.G. 25-Z	SLIDING GEAR 5TH G. 25-T	1
16	470.33.016.000	LOSRAD 1.G. 29-Z	IDLER GEAR 1ST G. 29-T	1
20	470.33.099.000	NADELKRANZ K15X19X105	NEEDLE BEARING K15X19X105	1
22	490.33.091.000	SEEGERRING AS20X1,75 DIN 471	CIRCLIP AS20X1,75	1
23	0471 150010	SICHERUNGSRING DIN0471-15X1	CIRCLIP DIN0471-15X1	1
27	0625 160026	RILLENKUGELLAGER 16002	BALL BEARING 16002	1
28	0625 062041	RILLENKUGELLAGER 6204 JR2 C4	BALL BEARING 6204 JR2 C4	1
29	470.33.029.013	KETTENRAD 13-Z 85 SX	ENGINE SPROCKET 13-T 85 SX	X
29	470.33.029.014	KETTENRAD 14-Z 85 SX	ENGINE SPROCKET 14-T 85 SX	1
30	470.33.030.000	DISTANZBÜCHSE KETTENRITZEL	SPACER FOR SPROCKET	1
31	460.33.031.000	O-RING 18,77X1,78	O-RING 18,77X1,78	1
32	0760 263570	WELLENDICHTRING 26X35X7 B	SHAFT SEAL RING 26X35X7 B	1
36	0417 210120	SPRENGRING SW21	CIRCLIP SW21	3
42	470.33.040.000	ANLAUFSCHIBE 15X25X1	STOP DISC 15X25X1	1
43	470.33.043.000	ANLAUFSCHIBE 15X25X0,5	STOP DISC 15X25X0,5	3



* = NEUTEIL / NEW PART

X = NACH BEDARF / AS REQUIRED

FIG	TEILNR/PARTNR	BEZEICHNUNG	DESCRIPTION	QTY
1	470.34.001.000	SCHALTGABEL 5./6. GANG 2003	SHIFT FORK 5TH/6TH GEAR 2003	1
2	470.34.002.000	SCHALTGABEL 2./3. GANG 2003	SHIFT FORK 2ND/3RD GEAR 2003	1
3	470.34.003.000	SCHALTGABEL 1./4. GANG 2003	SHIFT FORK 1ST/4TH GEAR 2003	1
5	470.34.005.044	SCHALTWELLE KPL. 85 SX 2003	SHIFTING SHAFT CPL. 85 SX 2003	1
9	460.34.009.000	DRUCKFEDER GLEITBLECH	PRESSURE SPRING SLIDER PLATE	1
10	470.34.091.000	DISTANZSCHEIBE 15X20X0,5	WASHER 15X20X0,5	1
11	0625 069020	RILLENKUGELLAGER 6902 15X28X7	BALL BEARING 6902 15X28X7	1
12	470.34.012.000	SCHALTWALZE 85 SX 2003	SHIFT ROLLER 85 SX 2003	1
13	470.34.092.000	DISTANZSCHEIBE 25X32X0,5	WASHER 25X32X0,5	1
14	460.34.014.000	RÜCKHOLFEDER	RETURN SPRING	1
15	470.34.015.000	SCHALTARRETIERUNG 85 SX 2003	SHIFT LOCATION DRUM 85 SX 2003	1
16	0015 060253	SK.BUNDSCHRAUBE M 6X25 SW=8	HH COLLAR SCREW M 6X25 WS=8	1
17	0402 061480	NADELROLLE DIN5402 NRB 6X14,8	NEEDLE ROLLER DIN5402 6X14,8	3
18	460.34.019.052	FEDER SCHALTSCHIENE	SPRING SHIFT RAIL 2001	4
19	470.34.019.000	SCHALTSCHIENE 85 SX 2003	SHIFTING RAIL 85 SX 2003	1
20	460.34.020.100	SCHALTSCHIENE 2001	SHIFT RAIL 2001	1
21	0625 618050	RILLENKUGELLAGER 61805 C3	BALL BEARING 61805 C3	1
23	460.34.023.100	ARRETIERHEBELFEDER 2001	LOCKING LEVER SPRING 2001	1
24	460.34.024.100	ARRETIERHEBEL KPL. 65 SX 2002	LOCKING LEVER CPL. 65 SX 2002	1
25	0799 100000	SICH.SCHEIBE DIN6799-RS10,0	TAB WASHER DIN6799-RS10,0	1
29	470.34.029.000	LAGERZAPFEN FÜR FEDER 2003	ARRESTER FOR SPRING 2003	1
30	0933 060205	SK.SCHRAUBE DIN933-M 6X20 10.9	HH SCREW DIN933 M6X20 10.9	1
31	470.34.031.000	SCHALTHEBEL 85 SX 2003	SHIFT LEVER 85 SX 2003	1
32	0760 142460	WELLENDICHTRING 14X24X6 B	SHAFT SEAL RING 14X24X6 B	1
33	546.32.095.000	NADELHÜLSE HK 1412 14,6X20X12	NEEDLE BEAR.HK 1412 14,6X20X12	1
34	470.33.043.000	ANLAUFSCHLEIBE 15X25X0,5	STOP DISC 15X25X0,5	1
41	502.33.041.000	NORDLOCKSCHLEIBEN M6 (PAAR) DAC	PAIR OF WASHERS M 6 NORDLOCK	1
50	502.32.050.001	STAHLSCHEIBE 6,4X17X3	STEEL WASHER 6,4X17X3	1

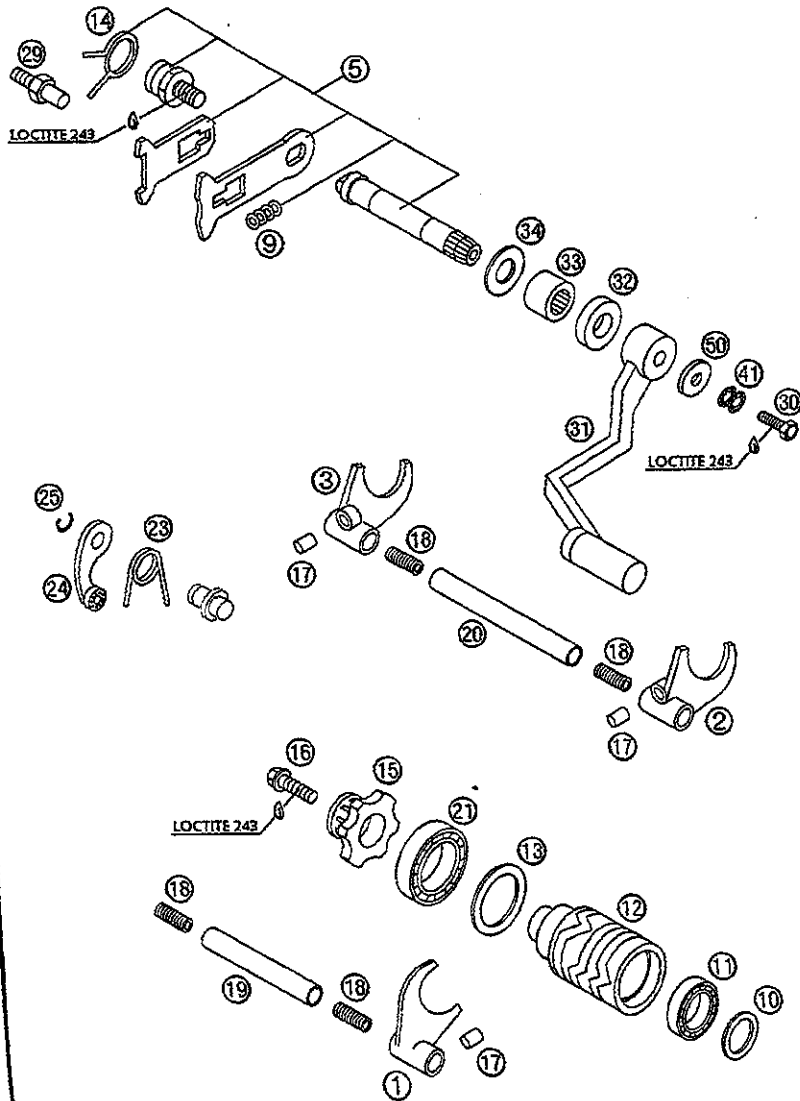


FIG	TEILNR/PARTNR	BEZEICHNUNG	DESCRIPTION	QTY
7	470.35.007.000	KÜHLER LINKS 85 SX 2003	RADIATOR L/S 85 SX 2003	1
8	470.35.008.000	KÜHLER RECHTS 85 SX 2003	RADIATOR R/S 85 SX 2003	1
9	590.35.009.000	KÜHLERVerschLUSS 1,4 BAR 2003	RADIAT.CAP 19,6PSI (1,4BAR) 03	1
20	100.01.020.000	SCHLAUCHKLEMMME GEMI 16-27	HOSE CLAMP GEMI 16-27	6
24	470.35.024.000	KÜHLERSCHLAUCH OBEN 85 SX 2003	RADIATOR HOSE TOP 85 SX 2003	1
25	470.35.025.000	KÜHLERSCHLAUCH UNTEN 85 SX 03	RADIATOR HOSE BOTTOM 85 SX 03	1
34	546.35.034.200	KÜHLERSCHUTZ LINKS FARBLOS '95	RADIATOR PROTECT.L/S COUL. '95	1
35	470.35.035.000	KÜHLERSCHUTZ RECHTS 85 SX 2003	RADIATOR PROTECT. R/S 85 SX 03	1
43	0021 060003	SCHEIBE DIN 9021 A 6,4	WASHER DIN9021-A 6,4	5
45	0015 060123	SK.BUNDSCHRAUBE M 6X12 SW=8	HH COLLAR SCREW M 6X12 WS=8	5
52	410.01.052.000	KABELTÜLLE D=12MM	RUBBER SLEEVE D=12MM	7

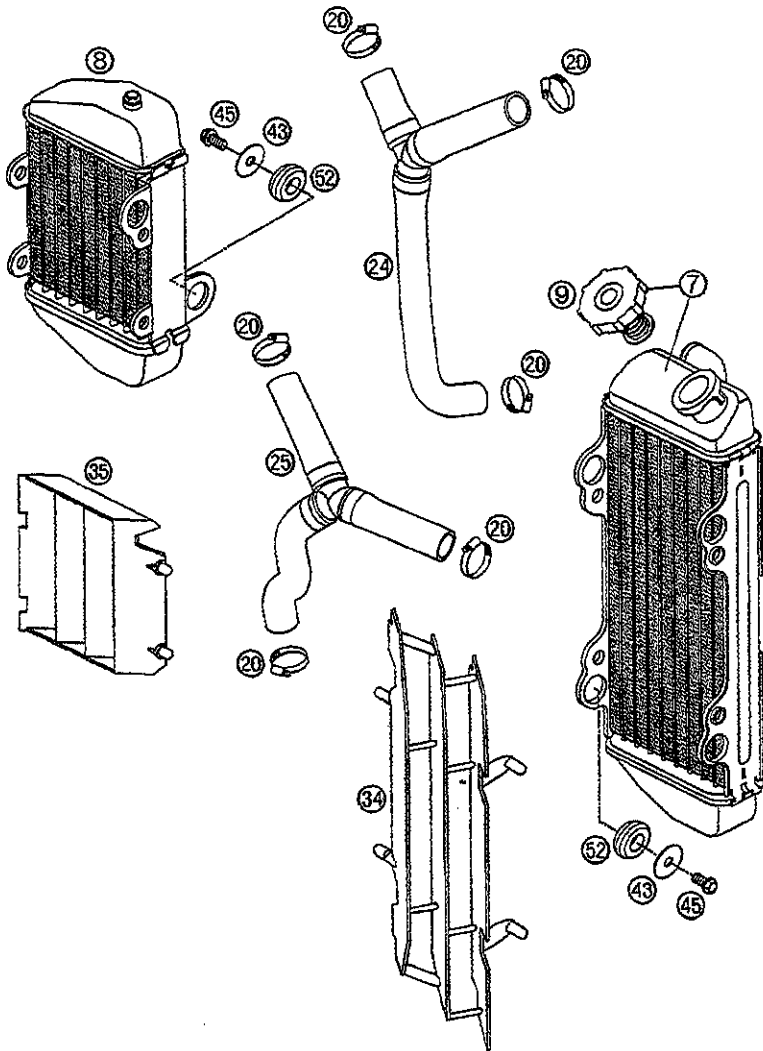
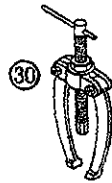
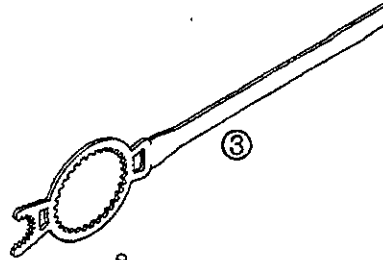
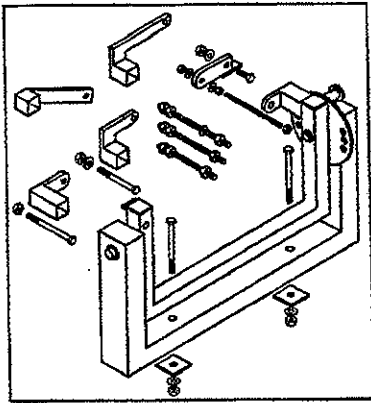
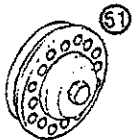
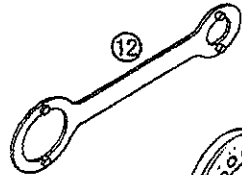
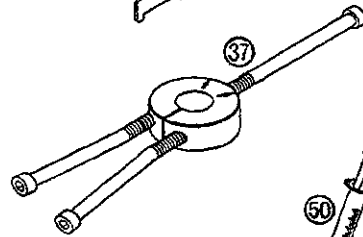
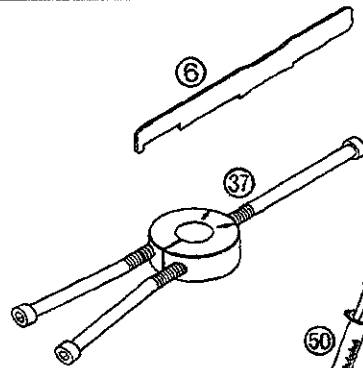
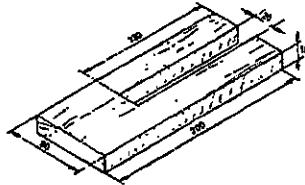


FIG	TEILNR/PARTNR	BEZEICHNUNG	DESCRIPTION	QTY
3	470.29.003.000	KUPPLUNGSHALTER 85 SX 2003	CLUTCH HOLDER 85 SX 2003	1
5	6 899 785	LOCTITE 243 BLAU 6CCM	LOCTITE 243 BLUE 6CCM	1
6	470.29.006.000	EINSTELLEHRE 85 SX 2003	ADJUSTING PLATE 85 SX 2003	1
9	546.29.009.044	MAGNETABZIEHER M 27X1 KOKUSAN	MAGNETIC PULLER M 27X1 KOKUSAN	1
11	510.12.011.000	SEEGERRINGZANGE VERKEHRT	SPECIAL CIRCLIP PLIER	1
12	546.29.012.100	HALTESCHLÜSS. ROTOR 2K-1/2/3/4	HOLD. SPANNER ROTOR 2K-1/2/3/4	1
13*	560.12.001.000	UNIVERSALMONTAGEBOCK '96	UNIVERSAL MOUNTING RACK '96	1
14*	151.12.018.200	EINSATZ 5-7 MM	INTERN.BEAR.PULLER 5-7 MM	1
16	510.12.016.000	SCHUTZKAPPE F. KURBELWELLE M12	PROTECTION CAP CRANKSHAFT M12	1
30*	151.12.017.000	LAGERAUSZIEHER	BUSHING EXTRACTOR	1
37	584.29.037.031	MONTAGEW.F.LAGERINNENR. NJ 205	MOUNTING TOOL INNER RING NJ205	1
50	503.29.050.000	ENTLÜFT.SPRITZE HYDR. KUPPLUNG	VENT INJEKTION HYDR. CLUTCH	1
51*	470.29.027.000	NIETWERKZEUG FÜR KUPPLUNG	RIVETTING TOOL FOR CLUTCH	1



HOLZGABEL
SELBSTGEFERTIGT
WOODEN FORK PLATE
HOME MADE



MOTOTECH
MOTORCYCLE TECHNOLOGY

MOTOTECH
MOTORCYCLE TECHNOLOGY



3208123

Artikel: 3208123 - 92000 - 1er. Auflage

KTM